

**Elettrovalvole ad azionamento diretto**  
 Direct acting solenoid valves  
 Elektroventile mit direkter Betätigung  
 Electrovanne a actionnement directe  
 Electroválvulas de accionamiento directo  
 Válvula Solenóide com acionamento direto



**SERIE 01F**

Pag. 4

**Elettrovalvole ad azionamento diretto in Acciaio AISI 316L**  
 Direct acting solenoid valves in Stainless Steel AISI 316L  
 Elektroventile mit direkter Betätigung Edelstahl AISI 316L  
 Electrovanne a actionnement directe en Acier inox AISI 316L  
 Electroválvulas de accionamiento directo en Acero inox AISI 316L  
 Válvula Solenóide com acionamento direto em Aço-inox AISI 316L

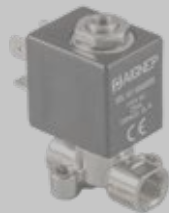

**SERIE X1F**

Pag. 17

**Elettrovalvole ad azionamento diretto**  
 Direct acting solenoid valves  
 Elektroventile mit direkter Betätigung  
 Electrovanne a actionnement directe  
 Electroválvulas de accionamiento directo  
 Válvula Solenóide com acionamento direto



**SERIE 02F**

Pag. 30

**Elettrovalvole ad azionamento diretto in Acciaio Inox AISI 316L**  
 Direct acting solenoid valves in Stainless Steel AISI 316L  
 Elektroventile mit direkter Betätigung Edelstahl AISI 316L  
 Electrovanne a actionnement directe en Acier inox AISI 316L  
 Electroválvulas de accionamiento directo en Acero inox AISI 316L  
 Válvula Solenóide com acionamento direto em Aço-inox AISI 316L



**SERIE X2F**

Pag. 47

**Elettrovalvole a membrana**  
 Membrane solenoid valves  
 Membranmagnetventile  
 Electrovanne a membrane  
 Electroválvulas accionamiento combinado  
 Válvula Solenóide com membrana



**SERIE 03F**

Pag. 60

**Elettrovalvole indirette**  
 Indirect acting solenoid valves  
 Indirektgesteuerte Elektroventile  
 Electrovanne à actionnement indirect  
 Electroválvulas de accionamiento indirecto  
 Válvula Solenóide com acionamento indireto



**SERIE 04F**

Pag. 67

**Elettrovalvole indirette in Acciaio Inox AISI 316L**  
 Indirect acting solenoid valves Stainless Steel AISI 316L  
 Indirektgesteuerte Elektroventile Edelstahl AISI 316L  
 Electrovanne à actionnement indirect Acier inox AISI 316L  
 Electroválvulas de accionamiento indirecto Acero inox AISI 316L  
 Válvula Solenóide com acionamento indireto Aço-inox AISI 316L



**SERIE X4F**

Pag. 78

**Valvola di Scarico Condensa - Condensed Drain Valve - Ablassventil**  
 Robinet de Vidange - Válvula de Vacío - Válvula de Drenagem

**Valvola Coassiale di Intercettazione - Coaxial Valve - Pneumatisches**  
 Axialventil - Vanne d'arrêt - Válvula de Cierre - Válvula de intercepção

**New**

**90975**  
Pag. 86

**New**

**90985**  
Pag. 87

**New**

**6056V**  
Pag. 95

Aignep si riserva il diritto di variare modelli e dimensioni senza preavviso - Aignep reserves the right to vary models and dimensions without notice - Aignep behält sich das Recht vor, Daten ohne Ankündigung zu ändern  
 Aignep se réserve le droit de modifier les données sans préavis - Aignep se reserva el derecho de modificar modelos y dimensiones sin previo aviso - Aignep reserva-se o direito de alterar os modelos e dimensões sem prévio aviso

**ELETTROVALVOLE PER FLUIDI**

*FLUID SOLENOID VALVES*

*ELEKTROVENTILE FÜR FLÜSSIGKEITEN*

*ELECTROVANNES POUR FLUIDES*

*ELECTROVÁLVULAS PARA FLUIDOS*

*VÁLVULA SOLENÓIDE PARA FLUIDOS*



**Serie 01F - X11F - 02F - X22F - 03F - 04F - X4F**

**New**

# VALVOLA DI SCARICO CONDENSA

CONDENSED DRAIN VALVE  
 ABLASSVENTIL  
 ROBINET DE VIDANGE  
 VÁLVULA DE VACIADO  
 VÁLVULA DE DRENAGEM



**CARATTERISTICHE TECNICHE**  
 TECHNICAL CHARACTERISTICS  
 TECHNISCHE ANGABEN  
 CARACTÉRISTIQUES TECHNIQUES  
 CARACTERÍSTICAS TÉCNICAS  
 CARACTERÍSTICAS TÉCNICAS

**2/2 NC**



**Materiali e Componenti**

**IT**

- 1 Corpo: Ottone
- 2 Guarnizioni: NBR
- 3 Tubo guida: Acciaio inox
- 4 Nucleo fisso e mobile: Acciaio inox
- 5 Molle: Acciaio inox

**Component Parts and Materials**

**GB**

- 1 Body: Brass
- 2 Seals: NBR
- 3 Welded armature tube: Stainless steel
- 4 Fixed and mobile core: Stainless steel
- 5 Springs: Stainless steel

**Komponenten und Materialien**

**DE**

- 1 Körper: Messing
- 2 Dichtung: NBR
- 3 Führungsrohr: Edelstahl
- 4 Kern: Edelstahl
- 5 Feder: Edelstahl

**Matériaux et Composants**

**FR**

- 1 Corps: Laiton
- 2 Joints: NBR
- 3 Tube de pilotage: Acier inox
- 4 Noyau: Acier inox
- 5 Ressort: Acier inox

**Materiales y componentes**

**ES**

- 1 Cuerpo: Latón
- 2 Juntas: NBR
- 3 Tubo guía: Acero inox.
- 4 Núcleo fijo y móvil: Acero inox.
- 5 Muelle: Acero inox.

**Materiais e Componentes**

**PT**

- 1 Corpo: Latão
- 2 Vedações: NBR
- 3 Tubo Guia: Aço-inox
- 4 Núcleo fixo e móvel: Aço-inox
- 5 Mola: Aço-inox



**Pressione massima ammissibile**

Maximum allowable pressure  
 Max. Betriebsdruck  
 Pression de service max.  
 Presión máxima admisible  
 Pressão máxima admissível

**16 bar**



**Temperatura ambiente con bobine di classe H**

Room temperature with coil class H  
 Raumtemperatur, mit Spule der Klasse H  
 Température ambiante, avec bobine classe H  
 Temperatura ambiente con bobina clase H  
 Temperatura ambiente com bobina de classe H

**- 20 °C  
 + 80 °C**



**Diametro operatore**

Operator diameter  
 Durchmesser Führungsrohr  
 Diamètre tube de pilotage  
 Diámetro operador  
 Diâmetro do operador

**13 mm**



**Grado di filtrazione**

Degree of filtration  
 Abscheidegrad  
 Degré de filtration  
 Grado de filtración  
 Grau de filtração

**500 µm**

**GUARNIZIONI**  
 SEALS  
 DICHTUNGEN  
 JOINTS  
 JUNTAS  
 VEDAÇÕES

**TEMPERATURA**  
 TEMPERATURE  
 TEMPERATUR  
 TEMPÉRATURE  
 TEMPERATURA

**FLUIDO**  
 MEDIUM  
 MEDIUM  
 FLUIDES  
 FLUIDO  
 FLUIDO

**NBR**

**-10°C**

**+90°C**

**Aria, acqua max 75 °C, oli minerali, gasoli**  
 Air, inert gas, water max 75 °C, mineral oils, gas oil  
 Luft, Edelgase, Wasser max. 75°C, Mineralöle, Diesel, Heizöl  
 Air, gas neutres, eau max. 75°C, huiles minerales, diesel  
 Aire, gas inerte, agua máx. 75°C., aceites minerales, gasóleo  
 Ar, gás inertes, água máx 75 °C, óleos minerais, gasóleo

**90975**

**VALVOLA DI SCARICO CONDENSA**

CONDENSED DRAIN VALVE  
 ABLASSVENTIL  
 ROBINET DE VIDANGE  
 VÁLVULA DE VACIADO  
 VÁLVULA DE DRENAGEM

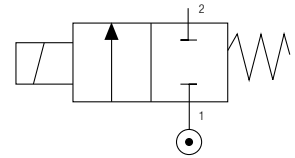

**2/2 NC**

Ø mm	Viscosità Viscosity Viskosität Viscosité Viscosidad Viscosidade	Kv m3/h	Potenza		ΔP bar	
			Function		Min	Max
	Max cSt		DC W	AC VA		
3	53	0.21	8	-	0	11.4
			14	-	0	15.1
			22	-	0	20
			-	14	0	10.6
			-	21	0	17.1
			-	31	0	24.1

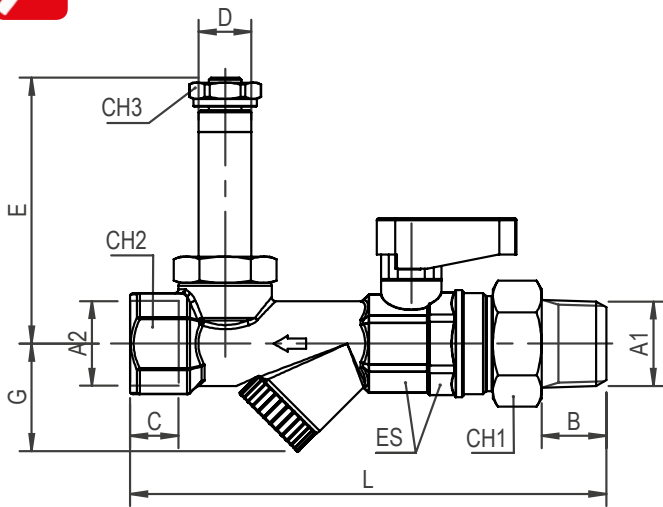

Code	A1	A2	B	C	D	CH1	CH2	CH3	L	E	ES	G
90975 00 004	3/8	1/2	11,5	12	13	27	25	16	113,5	65,5	22 - 23	26,5
90975 00 005	1/2	1/2	16	12	13	27	25	16	117,5	65,5	22 - 23	26,5

**SOLENOIDI + CONNETTORI (NO 12V)**

SOLENOIDS + CONNECTOR (NO 12V)  
 SPULEN + STECKER (NEIN 12V)  
 BOBINES + CONNECTEURS (NO 12V)  
 BOBINAS + CONECTORE (NO 12V)  
 SOLENÓIDES + CONECTOR (NO 12V)

**vedi pag: 57 - 59**

See page: 57 - 59  
 Siehe Seite: 57 - 59  
 Voir pag: 57 - 59  
 Ver pág: 57 - 59  
 Ver pág: 57 - 59

# 90985 00 001

## TEMPORIZZATORE ANALOGICO DIN43650A

ANALOGUE TIMER DIN43650A  
 TIMER ANALOG DIN43650A  
 TIMER ANALOG DIN43650A  
 ANALÓGICO TEMPORIZADOR DIN43650A  
 TIMER ANALOG DIN43650A



### Caratteristiche

Features

Features

Traits

Características

Recursos

- 24 - 240V AC/DC 50/60Hz
- IP65 - EN6052
- 1 A Max
- 0,5 - 10 Sec. ON
- 0,5 - 45 Min. OFF
- Reset/Test



### Temperatura

Temperature

Temperatur

Température

Temperatura

Temperatura

- 10 °C
- + 50 °C

# SOLENOIDI

SOLENOIDS  
SPULEN  
BOBINES  
BOBINAS  
SOLENOÍDES

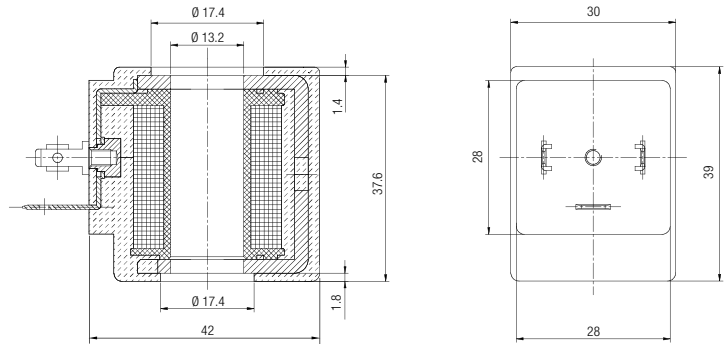

Codice Code Nummer Code Código Código	Diametro operatore Operator diameter Durchmesser Führungsrohr Diamètre tube de pilotage Diámetro operador Diâmetro do operador	Taglia Size Grösse Dimensions Talla Tamanho	Tensione Voltage Leistung Tension Tensión Tensão	Potenza Function Leistung Puissance Potencia Potência
SOL20 012 C 5 000	13	30	12V DC	8 w
SOL20 024 C 5 000	13	30	24V DC	8 w
SOL20 012 C 6 000	13	30	12V DC	14 w
SOL20 024 C 6 000	13	30	24V DC	14 w
SOL20 024 A A 000	13	30	24V AC	14 VA
SOL20 110 A A 000	13	30	110V AC	14 VA
SOL20 220 A A 000	13	30	220V AC	14 VA
SOL20 024 A B 000	13	30	24V AC	21 VA
SOL20 110 A B 000	13	30	110V AC	21 VA
SOL20 220 A B 000	13	30	220V AC	21 VA

**TOLLERANZE DI TENSIONE**

VOLTAGE TOLERANCE  
SPANNUNGSTOLERANZ  
TOLÉRENCE DE LA TENSION  
TOLERANCIA DE TENSIÓN  
TOLERÂNCIA DE TENSÃO

**±10 %**

**CLASSE DI ISOLAMENTO**

CLASS OF ISOLATION  
ISOLIERSTOFFKLASSE  
CLASSE D'ISOLATION  
CLASE DE AISLAMIENTO  
CLASSE DE ISOLAMENTO

**H CEI EN 60085**

**CICLO DI LAVORO**

DUTY RATE  
ARBEITSZYKLUS  
CYCLE DE SERVICE  
CICLO DE TRABAJO  
CICLO TRABALHO

**100 % ED**

**GRADO DI PROTEZIONE**

DEGREE OF PROTECTION  
SCHUTZART  
DEGRÉ DE PROTECTION  
GRADO DE PROTECCIÓN  
GRAU DE PROTEÇÃO

**IP65 IEC 60529**

con connettore  
with connector  
mit Stecker  
avec connecteur  
con connector  
com conector

**TERMINALI**

TERMINALS  
ANSCHLÜSSE  
CONNEXION  
TERMINALES  
TERMINAIS

**DIN 43650**

# CONNETTORE

CONNECTOR  
STECKER  
CONNECTEURS  
CONECTOR  
CONECTOR



**30-36**

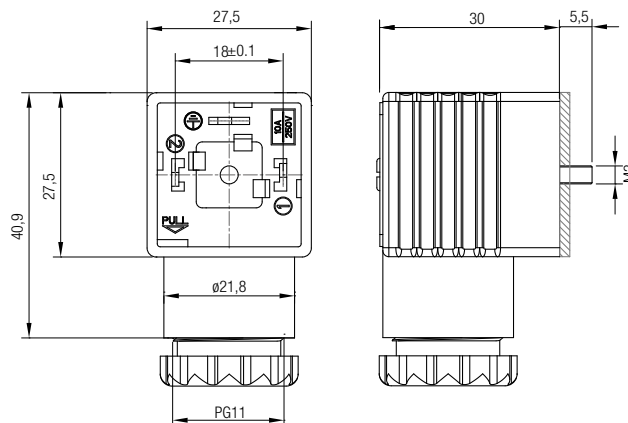

## Schema elettrico

Wiring

Elektroschema

Schéma électrique

Esquema eléctrico

Esquema elétrico

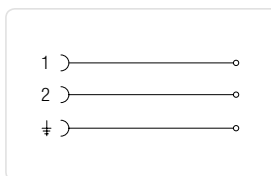

**CON31 000 01**

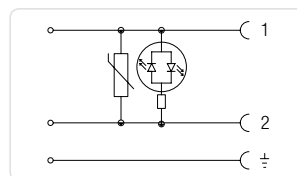

**CON32 024 00  
CON32 110 00  
CON32 250 00**

Code Code Nummer Code Código Código	Colore Colour Farbe Couleur Color Cor	Caratteristiche Characteristics Eigenschaften Caractéristiques Características Características	Taglia Size Größe Dimensions Talla Tamanho
<b>CON31 000 01</b>	■	2 POLI - PINS - PINS - BROCHES - PINS - PINOS	30-36
<b>CON32 024 00</b>	□	LED + VDR 0 - 24V	30-36
<b>CON32 110 00</b>	□	LED + VDR 110V	30-36
<b>CON32 250 00</b>	□	LED + VDR 220V	30-36

■ **NERO**  
BLACK  
SCHWARZ  
NOIR  
NEGRO  
PRETO

□ **TRASPARENTE**  
TRANSPARENT  
TRANSPARENT  
TRANSPARENT  
TRANSPARENTE  
TRANSPARENTE

**VDR:** Dotati di Varistore come dispositivo di protezione delle sovratensioni.  
Fitted with varistors as surge protection device.  
Ausgestattet mit Varistor als ÜberSpannungsschutz.  
Equipé avec varistance de protection contre les sur Tensions.  
Dotado de Varistor como dispositivo de protección de sobretensiones.  
Dotados de Varistor como dispositivo de proteção de sobretensão.

**GRADO DI PROTEZIONE**  
DEGREE OF PROTECTION  
SCHUTZART  
DEGRÉ DE PROTECTION  
GRADO DE PROTECCIÓN  
GRAU DE PROTEÇÃO

**IP65 IEC  
60529**

**DIAMETRO CAVO**  
CABLE DIAMETER  
KABELDURCHMESSER  
DIAMÈTRE DU CABLE  
DIÁMETRO CABLE  
DIÁMETRO DO CABO

**6÷8 mm  
for size  
22mm**  
**6÷8 mm e  
8÷11 for size  
30-36mm**

# CONNETTORE UL

CONNECTOR  
STECKER  
CONNECTEURS  
CONECTORE  
CONECTOR



 **30-36**

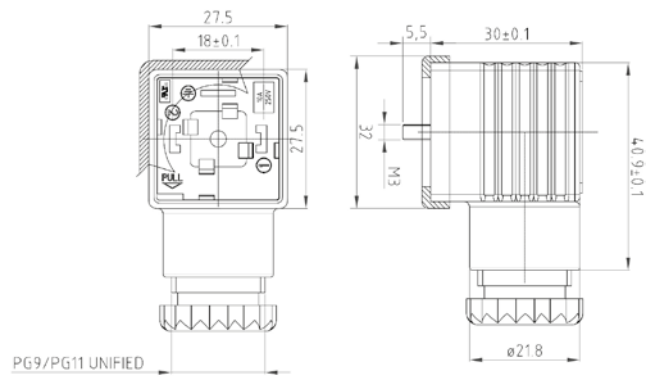

## UL 1977 AND CAN/CSA C22.2 NO. 182.3



Schema elettrico

Wiring

Elektroschema

Schéma électrique

Esquema eléctrico

Esquema elétrico

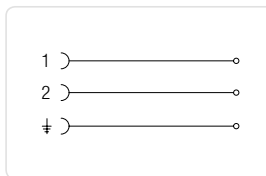

**CONU3 100 01**

Codice Code Nummer Code Código Código	Colore Colour Farbe Couleur Color Cor	Caratteristiche Characteristics Eigenschaften Caractéristiques Características Características	Taglia Size Größe Dimensions Talla Tamanho
<b>CONU3 100 01</b>		2 POLI - PINS - PINS - BROCHES - PINS - PINOS	30-36

 **NERO**  
BLACK  
SCHWARZ  
NOIR  
NEGRO  
PRETO

Guarnizione a profilo come previsto da certificazione UL/CSA.  
Profile gasket as required by UL/CSA certification.  
Profildichtung, wie es die UL/CSA-Zertifizierung verlangt.  
Joint de profil tel que requis par la certification UL/CSA.  
Junta del perfil según lo requerido por la certificación de UL/CSA.  
Gaxeta do perfil como exigido pela certificação de UL/CSA.

**GRADO DI PROTEZIONE**  
DEGREE OF PROTECTION  
SCHUTZART  
DEGRÉ DE PROTECTION  
GRADO DE PROTECCIÓN  
GRAU DE PROTEÇÃO

**IP65 IEC 60529**

**DIAMETRO CAVO**  
CABLE DIAMETER  
KABELDURCHMESSER  
DIAMÈTRE DU CABLE  
DIÁMETRO CABLE  
DIÁMETRO DO CABO

**6÷8 mm for size 22mm**  
**6÷8 mm e 8÷11 for size 30-36mm**

**TERMINALI**  
TERMINALS  
VERBINDUNG  
CONNEXION  
TERMINALES  
TERMINAIS

**INDUSTRIAL AMP 22 mm**  
**DIN 43650 30-36 mm**



**ACCESSORI FLUIDITY**

FLUIDITY ACCESSORIES  
ZUBEHÖR FLUIDITY  
ACCESSOIRES FLUIDITY  
ACCESORIOS FLUIDITY  
ACESSÓRIOS FLUIDITY

**03FK4**

**KIT MEMBRANA E O-RING SERIE 03F**

DIAPHRAGM KIT AND O-RING  
ERSATZMEMBRANE FÜR ELEKTROVENTILE UND O-RING  
MEMBRANE DE RECHANGE ET O-RING  
GRUPO MEMBRANA Y O-RING  
KIT DIAFRAGMA E O-RING



Codice Code Nummer Code Código Código	Guarnizioni Seals Dichtungen Joints Juntas Vedações	Taglia Size Größe Dimensions Talla Tamanho
03FK4 0 03 N 0	NBR	1/4
03FK4 0 03 V 0	FKM	1/4
03FK4 0 03 E 0	EPDM	1/4
03FK4 0 04 N 0	NBR	3/8 - 1/2
03FK4 0 04 V 0	FKM	3/8 - 1/2
03FK4 0 04 E 0	EPDM	3/8 - 1/2
03FK4 0 07 N 0	NBR	3/4
03FK4 0 07 V 0	FKM	3/4
03FK4 0 07 E 0	EPDM	3/4
03FK4 0 09 N 0	NBR	1"
03FK4 0 09 V 0	FKM	1"
03FK4 0 09 E 0	EPDM	1"

**04FK4**

**KIT MEMBRANA E O-RING SERIE 04F**

DIAPHRAGM KIT AND O-RING  
ERSATZMEMBRANE FÜR ELEKTROVENTILE UND O-RING  
MEMBRANE DE RECHANGE ET O-RING  
GRUPO MEMBRANA Y O-RING  
KIT DIAFRAGMA E O-RING



1/4  
3/8 - 1/2

3/4 - 1"  
1" 1/4 - 1" 1/2 - 2"

Codice Code Nummer Code Código Código	Guarnizioni Seals Dichtungen Joints Juntas Vedações	Taglia Size Größe Dimensions Talla Tamanho
04FK4 0 03 N 0	NBR	1/4
04FK4 0 03 V 0	FKM	1/4
04FK4 0 03 E 0	EPDM	1/4
04FK4 0 04 N 0	NBR	3/8 - 1/2 - Ø 12
04FK4 0 04 V 0	FKM	3/8 - 1/2 - Ø 12
04FK4 0 04 E 0	EPDM	3/8 - 1/2 - Ø 12
04FK4 0 Y3 N 0	NBR	3/8 - 1/2 - Ø 14
04FK4 0 Y3 V 0	FKM	3/8 - 1/2 - Ø 14
04FK4 0 Y3 E 0	EPDM	3/8 - 1/2 - Ø 14
04FK4 0 07 N 0	NBR	3/4
04FK4 0 07 V 0	FKM	3/4
04FK4 0 07 E 0	EPDM	3/4
04FK4 0 09 N 0	NBR	1"
04FK4 0 09 V 0	FKM	1"
04FK4 0 09 E 0	EPDM	1"
04FK4 0 XF N 0	NBR	1" 1/4 - 1" 1/2
04FK4 0 XF V 0	FKM	1" 1/4 - 1" 1/2
04FK4 0 XF E 0	EPDM	1" 1/4 - 1" 1/2
04FK4 0 XH N 0	NBR	2"
04FK4 0 XH V 0	FKM	2"
04FK4 0 XH E 0	EPDM	2"

## X4FK4

### KIT MEMBRANA INOX E O-RING SERIE X4F

DIAPHRAGM KIT AND O-RING  
ERSATZMEMBRANE FÜR ELEKTROVENTILE UND O-RING  
MEMBRANE DE RECHANGE ET O-RING  
GRUPO MEMBRANA Y O-RING  
KIT DIAFRAGMA E O-RING



1/4  
3/8 - 1/2

3/4 - 1"

Codice Code Nummer Code Código Código	Guarnizioni Seals Dichtungen Joints Juntas Vedações	Taglia Size Grösse Dimensions Talla Tamanho
X4FK4 0 03 N 0	NBR	1/4
X4FK4 0 03 V 0	FKM	1/4
X4FK4 0 03 E 0	EPDM	1/4
X4FK4 0 04 N 0	NBR	3/8 - 1/2 - Ø 12
X4FK4 0 04 V 0	FKM	3/8 - 1/2 - Ø 12
X4FK4 0 04 E 0	EPDM	3/8 - 1/2 - Ø 12
X4FK4 0 Y3 N 0	NBR	3/8 - 1/2 - Ø 14
X4FK4 0 Y3 V 0	FKM	3/8 - 1/2 - Ø 14
X4FK4 0 Y3 E 0	EPDM	3/8 - 1/2 - Ø 14
X4FK4 0 07 N 0	NBR	3/4
X4FK4 0 07 V 0	FKM	3/4
X4FK4 0 07 E 0	EPDM	3/4
X4FK4 0 09 N 0	NBR	1"
X4FK4 0 09 V 0	FKM	1"
X4FK4 0 09 E 0	EPDM	1"

## OPK04

### KIT OPERATORE 10 mm SERIE 01F - 04F - X1F - X4F

OPERATOR KIT  
FUHRUNGSROHR KIT  
TUBE DE PILOTAGE KIT  
OPERADOR KIT  
OPERADOR KIT



01F  
04F

01F  
X1F  
04F  
X4F

01F  
X1F

01F  
X1F

Codice Code Nummer Code Código Código	Guarnizioni Seals Dichtungen Joints Juntas Vedações	Taglia Size Grösse Dimensions Talla Tamanho
OPK04 NT B2 NC 00	NBR	2/2 NC
OPK04 VT B2 NC 00	FKM	2/2 NC
OPK04 ET B2 NC 00	EPDM	2/2 NC
OPK04 NT B2 NO 00	NBR	2/2 NO
OPK04 VT B2 NO 00	FKM	2/2 NO
OPK04 ET B2 NO 00	EPDM	2/2 NO
OPK04 NT B3 NC 00	NBR	3/2 NC
OPK04 VT B3 NC 00	FKM	3/2 NC
OPK04 ET B3 NC 00	EPDM	3/2 NC
OPK04 NT B3 NO 00	NBR	3/2 NO
OPK04 VT B3 NO 00	FKM	3/2 NO
OPK04 ET B3 NO 00	EPDM	3/2 NO

## OPK05

### KIT OPERATORE 13 MM SERIE 02F - 03F - X2F - 04F (1" 1/4 - 1" 1/2 - 2")

OPERATOR KIT  
FUHRUNGSROHR KIT  
TUBE DE PILOTAGE KIT  
OPERADOR KIT  
OPERADOR KIT



02F  
04F

02F  
X2F  
03F  
04F

02F  
X2F

02F  
X2F

Codice Code Nummer Code Código Código	Guarnizioni Seals Dichtungen Joints Juntas Vedações	Taglia Size Grösse Dimensions Talla Tamanho
OPK05 NT B2 NC 00	NBR	2/2 NC
OPK05 VT B2 NC 00	FKM	2/2 NC
OPK05 ET B2 NC 00	EPDM	2/2 NC
OPK05 NT B2 NO 00	NBR	2/2 NO
OPK05 VT B2 NO 00	FKM	2/2 NO
OPK05 ET B2 NO 00	EPDM	2/2 NO
OPK05 NT B3 NC 00	NBR	3/2 NC
OPK05 VT B3 NC00	FKM	3/2 NC
OPK05 ET B3 NC 00	EPDM	3/2 NC
OPK05 NT B3 NO 00	NBR	3/2 NO
OPK05 VT B3 NO 00	FKM	3/2 NO
OPK05 ET B3 NO 00	EPDM	3/2 NO

## OPK06-07

**New**

### KIT ANTICONDENSA IN FKM 2/2 - NC

ANTICONDENSATION KIT MADE IN FKM 2/2 - NC  
 FKM ANTIKONDENSAT KIT 2/2 - NC  
 KIT ANTI-BUÉE IN FKM 2/2 - NC  
 ANTICONDENSACIÓN KIT IN FKM 2/2 - NC  
 ANTICONDENSAÇÃO KIT IN FKM 2/2 - MC

Codice Code Nummer Code Código Código	Guarnizioni Seals Dichtungen Joints Juntas Vedações	Taglia e diametro solenoidi Size and diameter solenoids Grösse und durchmesser spulen Dimensions et Diamètre bobines Talla y Diámetro bobinas Tamanho e Diâmetro solenóides
<b>OPK06 VT B2 NC 22</b>	FKM	22 - Ø 10
<b>OPK06 VT B2 NC 30</b>	FKM	30 - Ø 10
<b>OPK07 VT B2 NC 30</b>	FKM	30/36 - Ø 13

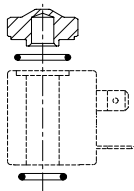

## VAL04

### VALIGETTA ESPOSITIVA

DEMO CASE  
 DEMONSTRATIONSKOFFER  
 COFFRE DE DÉMONSTRATION  
 MALETA EXPOSITOR  
 MALETA EXPOSITORA

Code	Pack.
<b>VAL04</b>	1



## COMPATIBILITA' CHIMICA "SERIE FLUIDITY"

CHEMICAL COMPATIBILITY  
 VEREINBARKEIT CHEMICAL  
 CHIMIQUE COMPATIBILITÉ  
 COMPATIBILIDAD QUÍMICA  
 COMPATIBILIDADE QUÍMICA

FLUIDS	BODY MATERIAL		SEALS		
	Brass	Stainless Steel AISI 316L	NBR	EPDM	FKM
<b>Acetone</b> - Acetone - Aceton - Acetone - Acétone - Acetone	●	●	●	●	●
<b>Acetylene</b> - Acetilene - Ethin - Acétylène - Acetileno - Acetileno	●	●	●	●	●
<b>Argon</b>	●	●	●	●	●
<b>Benzene</b> - Benzene - Benzol - Benzène - Benceno - Benzeno	●	●	●	●	●
<b>Butane</b> - Butano - n-Butan - Butane - Butano - Butano	●	●	●	●	●
<b>Carbon dioxide dry (gas)</b> - Anidride carbonica - Kohlendioxid trocken - dioxyde de carbone à sec - dióxido de carbono seco	●	●	●	●	●
<b>Carbon dioxide dry (liquid)</b> - Anidride carbonica - Kohlendioxid trocken - dioxyde de carbone à sec - dióxido de carbono seco	●	●	●	●	●
<b>Carbon disulfide</b> - Solfuro di carbonio - Kohlenstoffdisulfid - Disulfure de carbone - Sulfuro de carbono - Dissulfeto de carbono	●	●	●	●	●
<b>Chloroform (100%)</b> - Cloroformio - Chloroform - Chloroforme - Cloroformo - Clorofórmio	●	●	●	●	●
<b>Diesel fuel</b>	●	●	●	●	●
<b>Helium</b> - Elio - Helium - Hélium - Helio - Hélio	●	●	●	●	●
<b>Ethane</b> - Etano - Ethan - Éthane - Etano - Etano	●	●	●	●	●
<b>Ethanol</b> - Etanolo - Ethanol - Éthanol - Etanol - Etanol	●	●	●	●	●
<b>Ethyl acetate</b> - Acetato di etile - Essigsäureethylester - Acétate d'éthyle - Etanoato de etilo - Acetato de etila	●	●	●	●	●
<b>Ethyl chloride</b> - Cloruro di etile - Ethyl-Chlorid - Chlorure d'éthyle - Cloruro de etilo - Cloruro de etilo	●	●	●	●	●
<b>Ethylene glycol</b> - Glicole etilenico - Ethylenglykol - Éthylène glycol - Glicol de etileno - Etileno glicol	●	●	●	●	●
<b>Formaldehyde (100%)</b> - Formaldeide - Formaldehyd - Formaldéhyde - Formaldehído - Formaldeído	●	●	●	●	●
<b>Freon</b>	●	●	●	●	●
<b>Glycerine</b> - Glicerina - Glycerin - Glycérine - Glicerina - Glicerina	●	●	●	●	●
<b>Heptane</b> - Eptano - Heptan - Heptane - Heptano - Heptano	●	●	●	●	●
<b>Hexane</b> - Esano - Hexan - Hexane - Hexano - Hexano	●	●	●	●	●
<b>Hydrogen</b> - Idrogeno - Wasserstoff - Hydrogène - Hidrógeno - Hidrogénio	●	●	●	●	●
<b>Hydrogen peroxide</b> - Acqua Ossigenata - Wasserstoff-Peroxid - Peroxyde d'hydrogène - Peróxido de hidrógeno - Peróxido de hidrogénio	●	●	●	●	●
<b>Isobutane</b> - Isobutano - Isobutan - Isobutane - Isobutano - Isobutano	●	●	●	●	●
<b>Isopentane</b> - Isopentano - Isopentane - Isopentane - Isopentano - Isopentano	●	●	●	●	●
<b>Methane</b> - Metano - Methan - Méthane - Metano - Metano	●	●	●	●	●
<b>Methanol</b> - Metanolo - Methanol - Méthanol - Metanol - Metanol	●	●	●	●	●
<b>Methyl chloride</b> - Clorometano - Chlormethan - Chlorométhane - Clorometano - Clorometano	●	●	●	●	●
<b>Mineral oil</b> - Olio minerale - Mineralöl - Huile minérale - Aceite mineral - Óleo mineral	●	●	●	●	●
<b>Neon</b>	●	●	●	●	●
<b>Nitrobenzene</b> - Nitrobenzene - Nitrobenzol - Nitrobenzène - Nitrobenzeno - Nitrobenzeno	●	●	●	●	●
<b>Nitrogen</b> - Azoto - Stickstoff - Azote - Nitrógeno - Nitrogénio	●	●	●	●	●
<b>Oxygen</b> - Ossigeno - Sauerstoff - Oxygène - Oxígeno - Oxigénio	●	●	●	●	●
<b>Pentane</b> - Pentano - Pentan - Pentane - Pentano - Pentano	●	●	●	●	●
<b>Petrol</b> - Benzina - Benzin - Essence - Gasolina - Gasolina	●	●	●	●	●
<b>Propane (LPG)</b> - Propano (GPL) - Propan (LPG) - Propane (GPL) - Propano (GLP) - Propano (GPL)	●	●	●	●	●
<b>Propyl Alcohol</b> - Alcool Propilico - Propyl-Alkohol - Alcool Propylique - Alcohol Propílico - Álcool propílico	●	●	●	●	●
<b>Toluene</b> - Toluene - Toluol - Toluène - Tolueno - Tolueno	●	●	●	●	●
<b>Trichlorethylene dry</b> - Trielina - Trichlorethen - Trichloréthylène - Tricloroetileno - Tricloroetileno	●	●	●	●	●
<b>Vinegar</b> - Aceto - Essig - Vinaigre - Vinagre - Vinagre	●	●	●	●	●
<b>Water demineralized</b> - Acqua demineralizzata - Demineralisiertes Wasser - Eau purifiée - Agua desionizada - Água deionização	●	●	●	●	●
<b>Water (Hard)</b> - Acqua dura - Hartes Wasser - Eau dure - Agua dura - Água dura	●	●	●	●	●
<b>Water (Hot &lt;75°C)</b> - Acqua calda - Heißes Wasser - Eau chaude - Agua caliente - Água quente	●	●	●	●	●
<b>Water (Hot and steam &lt;140°C)</b> - Vapore e acqua calda - Dampf und Heißwasser - Vapeur et eau chaude - Vapor y agua caliente - Vapor e água quente	●	●	●	●	●
<b>Water with glycol</b> - Acqua con glicole - Wasser mit Glykol - Eau avec glycol - Agua con glicol - Água com glicol	●	●	●	●	●
<b>Xylene</b> - Xilene - Xylol - Xylène - Xileno - Xileno	●	●	●	●	●

**LEGEND:**

- **COMPATIBLE** - COMPATIBILE - KOMPATIBEL - COMPATIBLE - COMPATIBLE - COMPATÍVEL
- **INCOMPATIBLE** - INCOMPATIBILE - UNVEREINBAR - INCOMPATIBLE - INCOMPATIBLE - INCOMPATÍVEL
- **ASK TO TECHNICAL DEPARTMENT** - CHIEDERE ALL'UFFICIO TECNICO - KONTAKTIEREN SIE UNS - VEUILLEZ NOUS CONSULTER - CONTACTAR EL DEPARTAMENTO TÉCNICO - CONSULTE O DEPARTAMENTO TÉCNICO