

# Air Slide Table

*Series MXS*

ø6, ø8, ø12, ø16, ø20, ø25

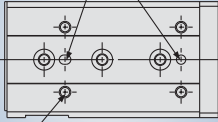


**Work table and air cylinder are compactly integrated.**

# Air slide table is suited for precision assembly.

## Improved workpiece mounting repeatability

Machined holes for positioning



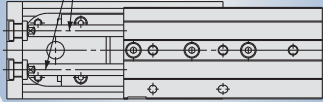
Thread for work mounting  
Helisert is used for improved strength.

## Flush mountable auto switches

An auto switch installed in the groove of the housing body is flush with the surface.

## Dual piston rod

The dual piston rod ensures twice the thrust of the current cylinder.



## Body mounting

Machined holes for positioning



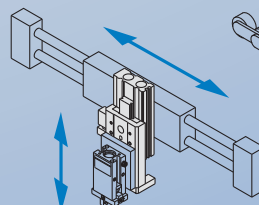
Threads for body mounting

## Mounting is possible from 3 directions.

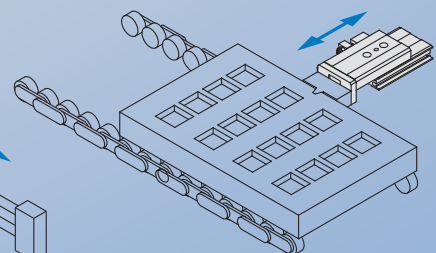
1. Lateral mounting (Body tapped)	2. Lateral mounting (Body through-hole)	3. Vertical mounting (Body tapped)

## Application examples

As X-axis for picking and placing



For positioning pallets on a conveyor



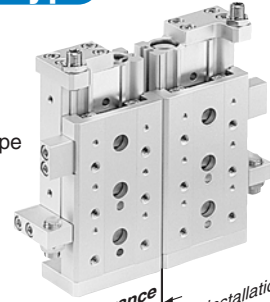
## Symmetric Type

Port location and stroke adjuster position are in opposite places from the standard body.

Standard type



Symmetric type



Small clearance  
Proximity installation of up to 5 mm is available. (MXS6)

## Wide variety of options

Adjuster option and function option can be combined.

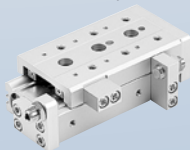
### Functional options

With buffer mechanism

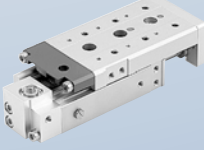


### Adjuster options

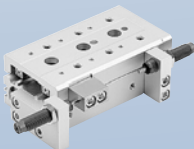
With stroke adjuster



With end lock



With shock absorber



Axial piping type



**Series Variations**

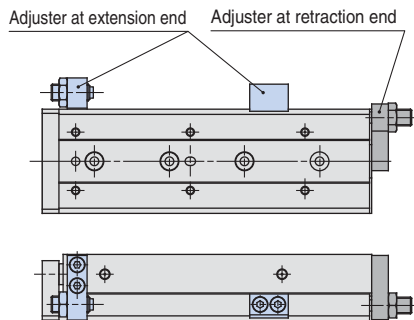
Model	Bore size (mm)	Standard stroke (mm)										Adjuster options		Functional options	Auto switch
		10	20	30	40	50	75	100	125	150	Stroke adjuster	With shock absorber adjuster (Except for ø6)			
MXS 6	6	●	●	●	●	●							Extension end	With buffer	Reed switch • D-A9□ • D-A9□V Solid state switch • D-M9□ • D-M9□V 2-colour indication solid state switch • D-M9□W • D-M9□WV
MXS 8	8	●	●	●	●	●						Retraction end			
MXS12	12	●	●	●	●	●									
MXS16	16	●	●	●	●	●									
MXS20	20	●	●	●	●	●									
MXS25	25	●	●	●	●	●									

**Adjuster Options**

**Stroke Adjuster**

- Adjustable stroke range: 0 to 5 mm

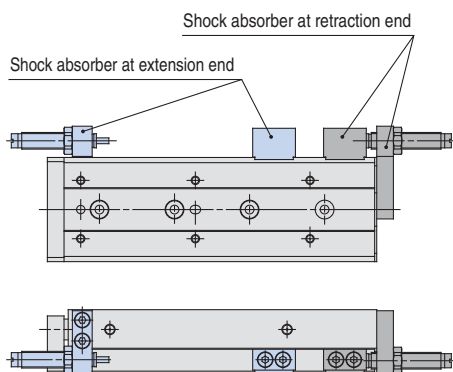
With adjuster at extension end (AS)  
With adjuster at retraction end (AT)  
With adjuster at both ends (A)



**With Shock Absorber**

- Absorbs the collision at stroke end and stops smoothly.
- Enables adjustment of stroke

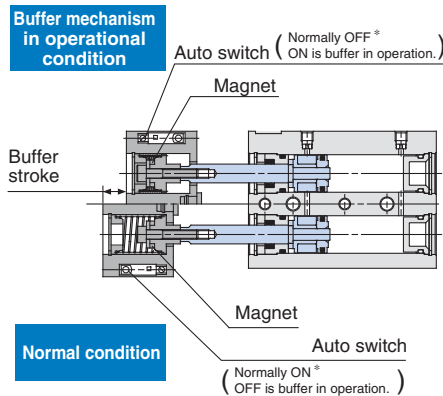
With shock absorber at extension end (BS)  
With shock absorber at retraction end (BT)  
With shock absorber at both ends (B)



**Functional Options**

**With Buffer Mechanism**

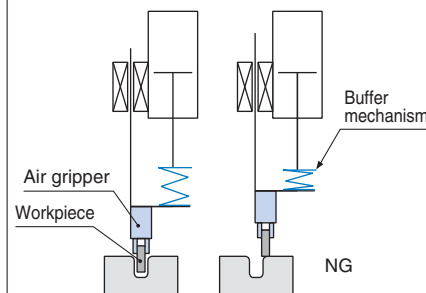
- Protects workpieces and tools, etc., by eliminating impact at the end of the extension stroke.
- Buffer unit is auto switch capable.



\* The normally ON/OFF setting is changed by changing the mounting direction of the auto switch.

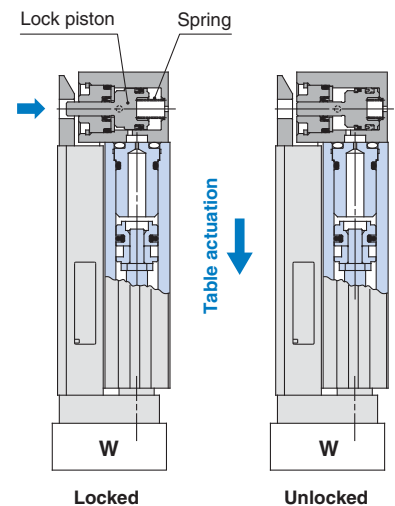
**Application Example**

Buffer mechanism absorbs shock and prevents damage to the workpiece in case the positioning is not accurate when a load is inserted.



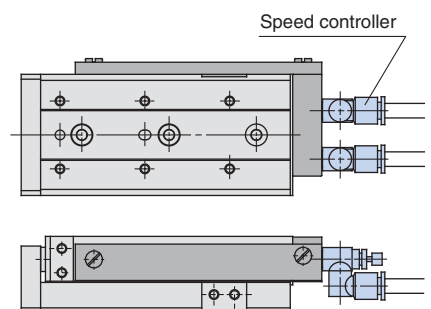
**With End Lock**

- Holds the cylinder's home position to prevent the workpiece from dropping even if the air supply is cut off.

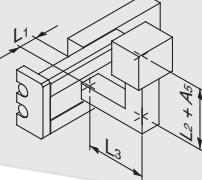


**Axial Piping Type**

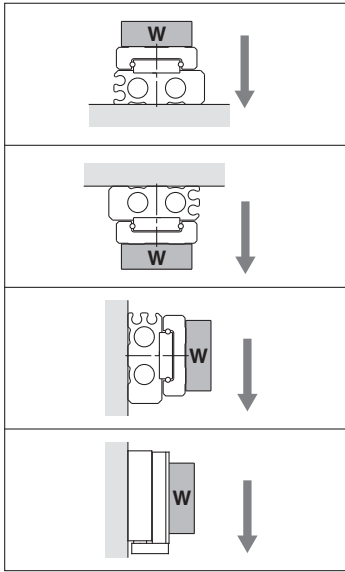
- Centralised piping in axial direction to maintain clear space around the body.



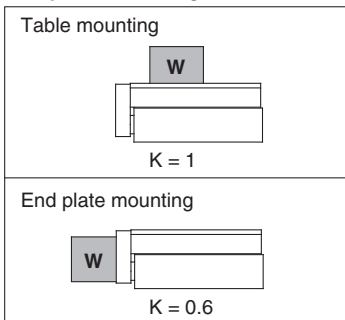
# Series MXS Model Selection

Model Selection Steps	Formula/Data	Selection Examples								
<p><b>1 Operating Conditions</b></p> <p>List the operating conditions considering the mounting position and workpiece configuration. Check that the load weight does not exceed the maximum allowable load weight and that the average operating speed does not exceed the operating speed range.</p>	<ul style="list-style-type: none"> <li>• Model to be used</li> <li>• Type of cushion</li> <li>• Workpiece mounting position</li> <li>• Mounting orientation</li> <li>• Average speed Va (mm/s)</li> <li>• Load weight W (kg): Fig. (1), Table (2)</li> <li>• Overhang Ln (mm): Fig. (2)</li> </ul>	 <p>Cylinder: MXS16-50 Cushion: Rubber bumper Workpiece table mounting Mounting: Horizontal wall mounting Average speed: Va = 300 [mm/s] Load weight: W = 1 [kg] L1 = 10 mm L2 = 30 mm L3 = 30 mm</p>								
<p><b>2 Kinetic Energy</b></p> <p>Find the kinetic energy E (J) of the load.</p> <p>Find the allowable kinetic energy Ea (J). Confirm that the kinetic energy of the load does not exceed the allowable kinetic energy.</p>	$E = \frac{1}{2} \cdot W \cdot \left(\frac{V}{1000}\right)^2$ <p>Collision speed <math>V = 1.4Va</math> *) Correction factor (Reference values)</p> <p><math>Ea = K \cdot Emax</math> Workpiece mounting coefficient K: Fig. (3) Max. allowable kinetic energy Emax: Table (1) Kinetic energy (E) Allowable kinetic energy (Ea)</p>	$E = \frac{1}{2} \cdot 1 \cdot \left(\frac{420}{1000}\right)^2 = 0.088$ <p><math>V = 1.4 \times 300 = 420</math> <math>Ea = 1 \times 0.11 = 0.11</math> Can be used based on <math>E = 0.088</math> <math>Ea = 0.11</math></p>								
<p><b>3 Load Factor</b></p>										
<p><b>3-1 Load Factor of Load Weight</b></p> <p>Find the allowable load weight Wa (kg). Note) There is no need to consider this load factor in the case of using perpendicularly in a vertical position. (Define <math>\alpha_1 = 0</math>.)</p> <p>Find the load factor of the load weight <math>\alpha_1</math>.</p>	<p><math>Wa = K \cdot \beta \cdot Wmax</math> Workpiece mounting coefficient K: Fig. (3) Allowable load weight coefficient <math>\beta</math>: Graph (1) Max. allowable load weight Wmax: Table (2)</p> <p><math>\alpha_1 = W/Wa</math></p>	<p><math>Wa = 1 \times 1 \times 4 = 4</math> K = 1 <math>\beta = 1</math> Wmax = 4 <math>\alpha_1 = 1/4 = 0.25</math></p>								
<p><b>3-2 Load Factor of Static Moment</b></p> <p>Find the static moment M (N·m).</p> <p>Find the allowable static moment Ma (N·m).</p> <p>Find the load factor <math>\alpha_2</math> of the static moment.</p>	<p><math>M = W \times 9.8 (Ln + An)/1000</math> Correction value of moment centre position distance An: Table (3)</p> <p><math>Ma = K \cdot \gamma \cdot Mmax</math> Workpiece mounting coefficient K: Fig. (3) Allowable moment coefficient <math>\gamma</math>: Graph (2) Maximum allowable moment Mmax: Table (4)</p> <p><math>\alpha_2 = M/Ma</math></p>	<table border="0"> <tr> <td style="border: 1px solid black; padding: 2px;">Yawing</td> <td style="border: 1px solid black; padding: 2px;">Rolling</td> </tr> <tr> <td>Examine My. <math>My = 1 \times 9.8 (10 + 30)/1000 = 0.39</math> <math>A_3 = 30</math></td> <td>Examine Mr. <math>Mr = 1 \times 9.8 (30 + 10)/1000 = 0.39</math> <math>A_6 = 10</math></td> </tr> <tr> <td><math>May = 1 \times 1 \times 15.9 = 15.9</math> Mymax = 15.9 K = 1 <math>\gamma = 1</math></td> <td><math>Mar = 15.9</math> (Same value as May)</td> </tr> <tr> <td><math>\alpha_2 = 0.39/15.9 = 0.025</math></td> <td><math>\alpha_2 = 0.39/15.9 = 0.025</math></td> </tr> </table>	Yawing	Rolling	Examine My. $My = 1 \times 9.8 (10 + 30)/1000 = 0.39$ $A_3 = 30$	Examine Mr. $Mr = 1 \times 9.8 (30 + 10)/1000 = 0.39$ $A_6 = 10$	$May = 1 \times 1 \times 15.9 = 15.9$ Mymax = 15.9 K = 1 $\gamma = 1$	$Mar = 15.9$ (Same value as May)	$\alpha_2 = 0.39/15.9 = 0.025$	$\alpha_2 = 0.39/15.9 = 0.025$
Yawing	Rolling									
Examine My. $My = 1 \times 9.8 (10 + 30)/1000 = 0.39$ $A_3 = 30$	Examine Mr. $Mr = 1 \times 9.8 (30 + 10)/1000 = 0.39$ $A_6 = 10$									
$May = 1 \times 1 \times 15.9 = 15.9$ Mymax = 15.9 K = 1 $\gamma = 1$	$Mar = 15.9$ (Same value as May)									
$\alpha_2 = 0.39/15.9 = 0.025$	$\alpha_2 = 0.39/15.9 = 0.025$									
<p><b>3-3 Load Factor of Dynamic Moment</b></p> <p>Find the dynamic moment Me (N·m).</p> <p>Find the allowable dynamic moment Mea (N·m).</p> <p>Find the load factor <math>\alpha_3</math> of the dynamic moment.</p>	<p><math>Me = 1/3 \cdot We \times 9.8 \frac{(Ln + An)}{1000}</math> Collision equivalent to impact <math>We = \delta \cdot W \cdot V</math> <math>\delta</math>: Bumper coefficient With urethane bumper (Standard) = 4/100 With shock absorber = 1/100 Correction value of moment centre position distance An: Table (3)</p> <p><math>Mea = K \cdot \gamma \cdot Mmax</math> Workpiece mounting coefficient K: Fig. (3) Allowable moment coefficient <math>\gamma</math>: Graph (2) Max. allowable moment Mmax: Table (4)</p> <p><math>\alpha_3 = Me/Mea</math></p>	<table border="0"> <tr> <td style="border: 1px solid black; padding: 2px;">Pitching</td> <td>Examine Mep. <math>Mep = 1/3 \times 16.8 \times 9.8 \times \frac{(30 + 10)}{1000} = 2.2</math> We = 4/100 x 10 x 420 = 16.8 A2 = 10 Meap = 1 x 0.7 x 15.9 = 11.1 K = 1 <math>\gamma = 0.7</math> Mpmax = 15.9 <math>\alpha_3 = 2.2/11.1 = 0.20</math></td> </tr> <tr> <td style="border: 1px solid black; padding: 2px;">Yawing</td> <td>Examine Mey. <math>Mey = 1/3 \times 16.8 \times 9.8 \times \frac{(30 + 31)}{1000} = 3.3</math> We = 16.8 A4 = 31 Meay = 11.1 (Same value as Meap) <math>\alpha_3 = 3.3/11.1 = 0.30</math></td> </tr> </table>	Pitching	Examine Mep. $Mep = 1/3 \times 16.8 \times 9.8 \times \frac{(30 + 10)}{1000} = 2.2$ We = 4/100 x 10 x 420 = 16.8 A2 = 10 Meap = 1 x 0.7 x 15.9 = 11.1 K = 1 $\gamma = 0.7$ Mpmax = 15.9 $\alpha_3 = 2.2/11.1 = 0.20$	Yawing	Examine Mey. $Mey = 1/3 \times 16.8 \times 9.8 \times \frac{(30 + 31)}{1000} = 3.3$ We = 16.8 A4 = 31 Meay = 11.1 (Same value as Meap) $\alpha_3 = 3.3/11.1 = 0.30$				
Pitching	Examine Mep. $Mep = 1/3 \times 16.8 \times 9.8 \times \frac{(30 + 10)}{1000} = 2.2$ We = 4/100 x 10 x 420 = 16.8 A2 = 10 Meap = 1 x 0.7 x 15.9 = 11.1 K = 1 $\gamma = 0.7$ Mpmax = 15.9 $\alpha_3 = 2.2/11.1 = 0.20$									
Yawing	Examine Mey. $Mey = 1/3 \times 16.8 \times 9.8 \times \frac{(30 + 31)}{1000} = 3.3$ We = 16.8 A4 = 31 Meay = 11.1 (Same value as Meap) $\alpha_3 = 3.3/11.1 = 0.30$									
<p><b>3-4 Sum of Load Factors</b></p> <p>Possible to use if the sum of the load factors does not exceed 1.</p>	<p><math>\sum \alpha_n = \alpha_1 + \alpha_2 + \alpha_3 \leq 1</math></p>	<p><math>\sum \alpha_n = \alpha_1 + \alpha_2 + \alpha_2' + \alpha_3 + \alpha_3'</math> <math>= 0.25 + 0.025 + 0.025 + 0.20 + 0.30 = 0.80 \leq 1</math> And it is possible to use.</p>								

**Fig. (1) Load Weight: W (kg)**



**Fig. (3) Workpiece Mounting Coefficient: K**



**Table (2) Maximum Allowable Load Weight: Wmax (kg)**

Model	Maximum allowable load weight
<b>MXS6</b>	0.6
<b>MXS8</b>	1
<b>MXS12</b>	2
<b>MXS16</b>	4
<b>MXS20</b>	6
<b>MXS25</b>	9

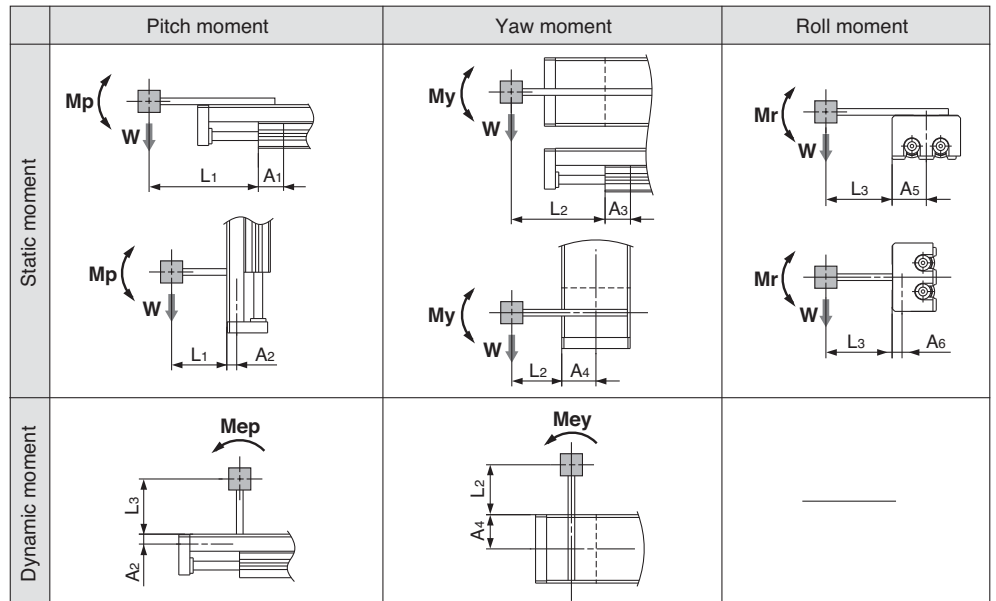
**Table (4) Maximum Allowable Moment: Mmax (N·m)**

Model	Stroke (mm)									
	10	20	30	40	50	75	100	125	150	
<b>MXS6</b>	0.7	1.0	1.2	1.2	1.2	—	—	—	—	
<b>MXS8</b>	2.0	2.0	2.8	3.6	4.2	4.2	—	—	—	
<b>MXS12</b>	4.2	4.2	4.2	5.8	7.0	10.0	10.0	—	—	
<b>MXS16</b>	11.3	11.3	11.3	11.3	15.9	25.0	34.1	34.1	—	
<b>MXS20</b>	19.4	19.4	19.4	19.4	27.2	35.0	50.5	50.5	50.5	
<b>MXS25</b>	30.6	30.6	30.6	30.6	42.8	55.1	67.3	67.3	67.3	

**Symbol**

Symbol	Definition	Unit	Symbol	Definition	Unit
<b>An (n = 1 to 6)</b>	Correction value of moment centre position distance	mm	<b>Va</b>	Average speed	mm/s
<b>E</b>	Kinetic energy	J	<b>W</b>	Load weight	kg
<b>Ea</b>	Allowable kinetic energy	J	<b>Wa</b>	Allowable load weight	kg
<b>Emax</b>	Max. allowable kinetic energy	J	<b>We</b>	Weight equivalent to impact	kg
<b>Ln (n = 1 to 3)</b>	Overhang	mm	<b>Wmax</b>	Max. allowable load weight	kg
<b>M (Mp, My, Mr)</b>	Static moment (Pitch, Yaw, Roll)	N·m	$\alpha$	Load factor	—
<b>Ma (Map, May, Mar)</b>	Allowable static moment (Pitch, Yaw, Roll)	N·m	$\beta$	Allowable load weight coefficient	—
<b>Me (Mep, Mey)</b>	Dynamic moment (Pitch, Yaw)	N·m	$\gamma$	Allowable moment coefficient	—
<b>Mea (Meap, Meay)</b>	Allowable dynamic moment (Pitch, Yaw)	N·m	$\delta$	Damper coefficient	—
<b>Mmax (Mpmmax, Mymmax, Mrmax)</b>	Max. allowable moment (Pitch, Yaw, Roll)	N·m	<b>K</b>	Workpiece mounting coefficient	—
<b>V</b>	Collision speed	mm/s			

**Fig. (2) Overhang: Ln (mm), Correction Value of Moment Centre Position Distance: An (mm)**



Note) Static moment: Moment generated by gravity  
Dynamic moment: Moment generated by impact when colliding with stopper

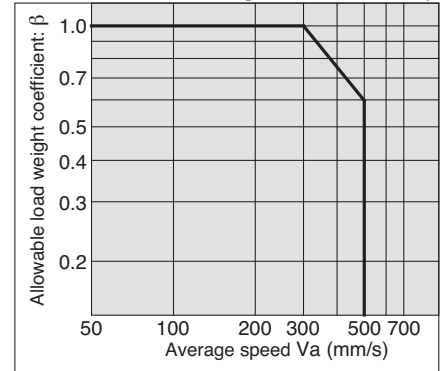
**Table (1) Maximum Allowable Kinetic Energy: Emax (J)**

Model	Allowable kinetic energy	
	Rubber bumper	Shock absorber
<b>MXS6</b>	0.018	—
<b>MXS8</b>	0.027	0.045
<b>MXS12</b>	0.055	0.11
<b>MXS16</b>	0.11	0.22
<b>MXS20</b>	0.16	0.32
<b>MXS25</b>	0.24	0.48

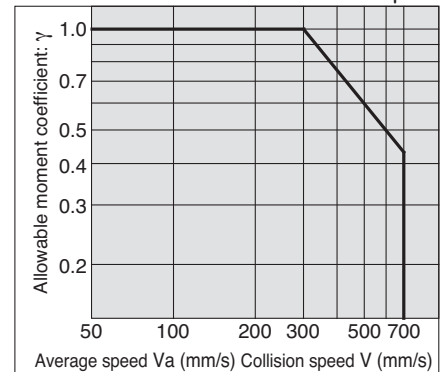
**Table (3) Correction Value of Moment Centre Position Distance : An (mm)**

Model	Correction value of moment centre position distance (Refer to Figure 2.)					
	A1	A2	A3	A4	A5	A6
<b>MXS6</b>	11	6	13	16	16	6
<b>MXS8</b>	11	7.5	13	20	20	7.5
<b>MXS12</b>	24	8.5	26	25	25	8.5
<b>MXS16</b>	27	10	30	31	31	10
<b>MXS20</b>	34	14.5	36	38	38	14.5
<b>MXS25</b>	42	19	44	46	46	19

**Graph (1) Allowable Load Weight Coefficient:  $\beta$**



**Graph (2) Allowable Moment Coefficient:  $\gamma$**



Note) Use the average speed when calculating static moment.  
Use the collision speed when calculating dynamic moment.

# Air Slide Table Series *MXS*

## How to Order

Air slide table

**MXS 12** **50** **AS** **FR** **M9N** **S**

### Port thread type

-	M	ø6 to ø16
	Rc	
<b>TN</b>	NPT	ø20, ø25
<b>TF</b>	G	

### Bore size (Stroke (mm))

<b>6</b>	10, 20, 30, 40, 50
<b>8</b>	10, 20, 30, 40, 50, 75
<b>12</b>	10, 20, 30, 40, 50, 75, 100
<b>16</b>	10, 20, 30, 40, 50, 75, 100, 125
<b>20</b>	10, 20, 30, 40, 50, 75, 100, 125, 150
<b>25</b>	10, 20, 30, 40, 50, 75, 100, 125, 150

### Adjuster option

-	Without adjuster
<b>AS</b>	Adjuster on extension end
<b>AT</b>	Adjuster on retraction end
<b>A</b>	Adjuster on both ends
<b>BS<sup>(1)</sup></b>	Absorber on extension end
<b>BT<sup>(1)</sup></b>	Absorber on retraction end
<b>B<sup>(1)</sup></b>	Absorber on both ends

Note 1) Options BS, BT and B are not available with the MXS6 series.

### Number of auto switches

-	2 pcs.
<b>S</b>	1 pc.
<b>n</b>	"n" pcs.

### Auto switch

-	Without auto switch
---	---------------------

\* For the applicable auto switch models, refer to the table below. For the applicable auto switches for buffer, refer to page 22.

### Functional option

-	Standard
<b>F</b>	With buffer
<b>R<sup>(2)</sup></b>	With end lock
<b>P</b>	Axial piping type
<b>FR<sup>(2)</sup></b>	With buffer and end lock
<b>FP</b>	With buffer, Axial piping type

Note 2) Option R is not available with the MXS6 series.

### Option Combinations

Adjuster option	Functional option					
	Nil	F	R	P	FR	FP
-	○	○	○	○	○	○
<b>AS</b>	○	○ <sup>(3)</sup>	○	○	○ <sup>(3)</sup>	○ <sup>(3)</sup>
<b>AT</b>	○	○	×	×	×	×
<b>A</b>	○	○ <sup>(3)</sup>	×	×	×	×
<b>BS</b>	○	×	○	○	×	×
<b>BT</b>	○	○	×	×	×	×
<b>B</b>	○	×	×	×	×	×

○: Available ×: Not available

Note 3) When the buffer mechanism and the stroke adjuster on extension end are combined, the buffer stroke will be shorter by the length adjusted by the stroke adjuster on the extension end.

**Applicable Auto Switches**/Refer to "SMC Best Pneumatics" catalogue for further information on auto switches.

Type	Special function	Electrical entry	Indicator light	Wiring (Output)	Load voltage			Auto switch model		Lead wire length <sup>*</sup> (m)			Pre-wired connector	Applicable load	
					DC	AC	Perpendicular	In-line	0.5 (Nil)	3 (L)	5 (Z)	IC circuit		Relay, PLC	
Reed switch	—	Grommet	Yes	3-wire (NPN equivalent)	—	5 V	—	<b>A96V</b>	<b>A96</b>	●	●		—		—
				2-wire	24 V	12 V	100 V	<b>A93V</b>	<b>A93</b>	●	●	—	—	—	Relay, PLC
Solid state switch	—	Grommet	Yes	3-wire (NPN)	24 V	5 V, 12 V	—	<b>M9NV</b>	<b>M9N</b>	●	●	○	○	IC circuit	Relay, PLC
				3-wire (PNP)				<b>M9PV</b>	<b>M9P</b>	●	●	○	○		
				2-wire				<b>M9BV</b>	<b>M9B</b>	●	●	○	○	—	
				3-wire (NPN)				<b>M9NVV</b>	<b>M9NV</b>	●	●	○	○	IC circuit	
				3-wire (PNP)				<b>M9PVV</b>	<b>M9PV</b>	●	●	○	○		
				2-wire				<b>M9BVV</b>	<b>M9BV</b>	●	●	○	○	—	

\* Lead wire length symbols: 0.5 m..... Nil (Example) M9N  
3 m..... L (Example) M9NL  
5 m..... Z (Example) M9NZ

\* Solid state switches marked with "○" are produced upon receipt of order.

- Since there are additional applicable auto switches than are listed, refer to page 31 for details.
- For details on auto switches with a pre-wired connector, refer to "SMC Best Pneumatics" catalogue.

### Specifications



Bore size (mm)	6	8	12	16	20	25
Piping port size	M3	M5			Rc1/8, NPT1/8, G1/8	
Fluid	Air					
Action	Double acting					
Operating pressure	0.15 to 0.7 MPa					
Proof pressure	1.05 MPa					
Ambient and fluid temperature	-10 to 60°C					
Piston speed	50 to 500 mm/s					
Cushion	Rubber bumper (Standard, With stroke adjuster) Shock absorber (Optional)					
Lubrication	Non-lube					
Auto switch (Optional)	Reed switch (2-wire, 3-wire) Solid state switch (2-wire, 3-wire) 2-colour indication solid state switch (2-wire, 3-wire)					
Stroke length tolerance	$+1_0$ mm					

### Option

Adjuster options	With stroke adjuster	Extension end (AS)	Stroke adjustment range 0 to 5 mm
		Retraction end (AT)	
		Adjuster on both ends (A)	
With shock absorber	Extension end (BS)	W/ shock absorber is not available with the MXS6 series.	
	Retraction end (BT)		
	Absorber on both ends (B)		
Functional options	With buffer (F)	W/ end lock is not available with the MXS6 series.	
	With end lock (R)		
	Axial piping type (P)		



\* For details of adjuster and functional option, refer to "Optional Specifications" on pages 19 to 22.



**Made to Order**  
(For details, refer to page 32.)

Symbol	Specifications
-X42	Anti-corrosive specifications for guide unit

For clean room specifications, refer to "Pneumatic Clean Series" catalogue.

### Standard Stroke

Model	Standard stroke (mm)
MXS6	10, 20, 30, 40, 50
MXS8	10, 20, 30, 40, 50, 75
MXS12	10, 20, 30, 40, 50, 75, 100
MXS16	10, 20, 30, 40, 50, 75, 100, 125
MXS20	10, 20, 30, 40, 50, 75, 100, 125, 150
MXS25	10, 20, 30, 40, 50, 75, 100, 125, 150

### Weight

Model	Standard stroke (mm)									Additional weight of adjuster option				Additional weight of functional option		
	10	20	30	40	50	75	100	125	150	Rubber stopper		Shock absorber		With buffer	With end lock	Axial piping type S: Stroke (mm)
										Extension end	Retraction end	Extension end	Retraction end			
MXS6 (L)	80	100	115	155	180	—	—	—	—	10	5	—	—	30	—	13+0.15S
MXS8 (L)	150	160	190	235	285	410	—	—	—	15	9	35	45	40	40	26+0.17S
MXS12 (L)	325	325	325	385	480	660	890	—	—	30	20	50	60	80	90	43+0.21S
MXS16 (L)	570	570	580	640	760	1090	1370	1700	—	50	30	80	105	120	160	55+0.21S
MXS20 (L)	960	980	1010	1100	1250	1630	2150	2670	3190	100	71	170	205	140	310	166+0.45S
MXS25 (L)	1660	1680	1690	1840	2090	2650	3270	4140	4710	150	125	215	300	240	540	240+0.45S

### Theoretical Output



The dual rod ensures an output twice that of existing cylinders. (N)

Bore size (mm)	Rod size (mm)	Operating direction	Piston area (mm <sup>2</sup> )	Operating pressure (MPa)					
				0.2	0.3	0.4	0.5	0.6	0.7
6	3	OUT	57	11	17	23	29	34	40
		IN	42	8	13	17	21	25	29
8	4	OUT	101	20	30	40	51	61	71
		IN	75	15	23	30	38	45	53
12	6	OUT	226	45	68	90	113	136	158
		IN	170	34	51	68	85	102	119
16	8	OUT	402	80	121	161	201	241	281
		IN	302	60	91	121	151	181	211
20	10	OUT	628	126	188	251	314	377	440
		IN	471	94	141	188	236	283	330
25	12	OUT	982	196	295	393	491	589	687
		IN	756	151	227	302	378	454	529

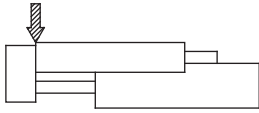
Note) Theoretical output (N) = Pressure (MPa) x Piston area (mm<sup>2</sup>)

(g)

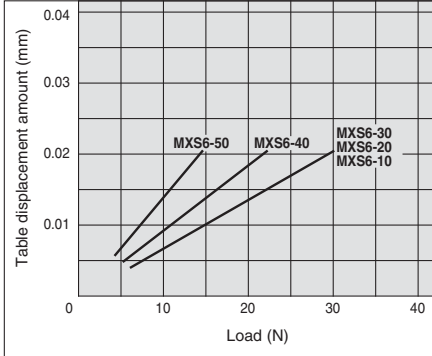
## Table Deflection (Reference values)

### Table displacement due to pitch moment load

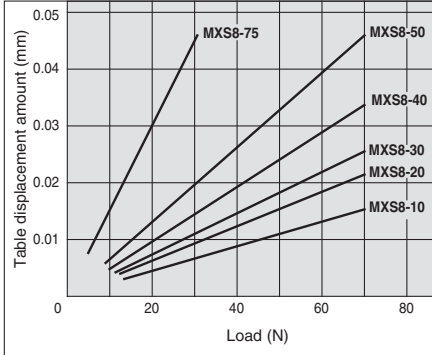
Deflection at the arrow mark when a load is applied to the arrow mark with the slide table fully extended.



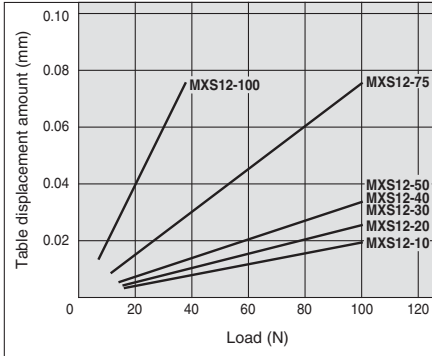
**ø6**



**ø8**

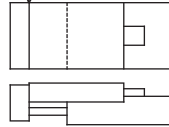


**ø12**

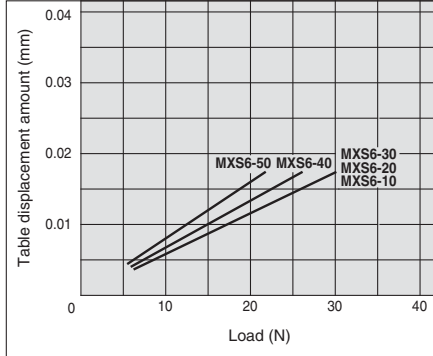


### Table displacement due to yaw moment load

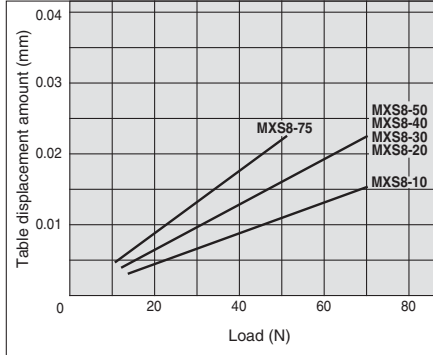
Deflection at the arrow mark when a load is applied to the arrow mark with the slide table fully extended.



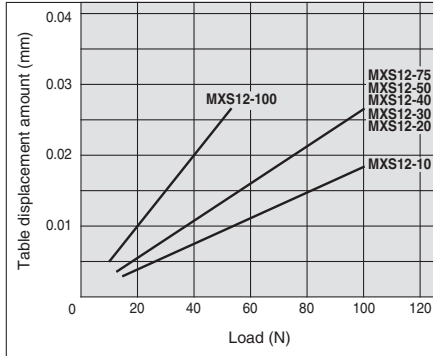
**ø6**



**ø8**

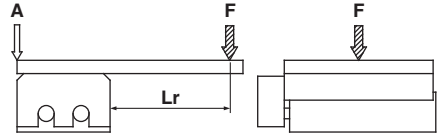


**ø12**

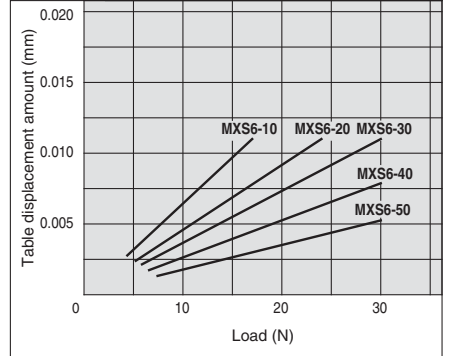


### Table displacement due to roll moment load

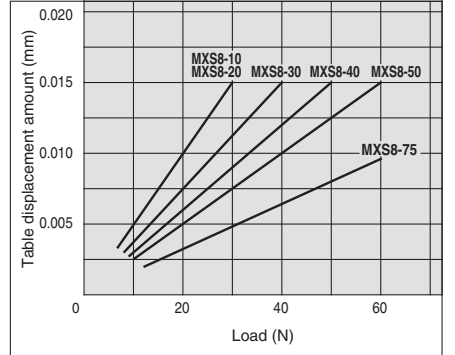
Displacement at "A" when a load is applied to "F" with the slide table retracted.



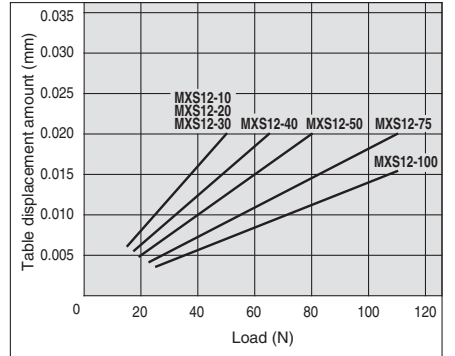
**ø6**



**ø8**



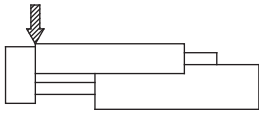
**ø12**



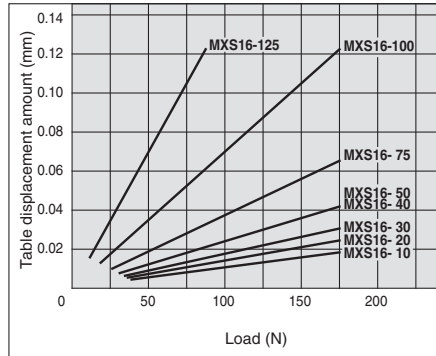


**Table displacement due to pitch moment load**

Deflection at the arrow mark when a load is applied to the arrow mark with the slide table fully extended.

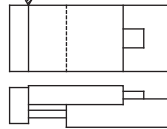


**ø16**

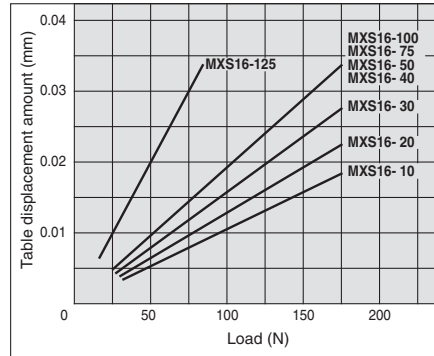


**Table displacement due to yaw moment load**

Deflection at the arrow mark when a load is applied to the arrow mark with the slide table fully extended.

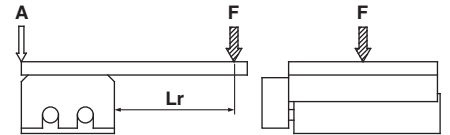


**ø16**

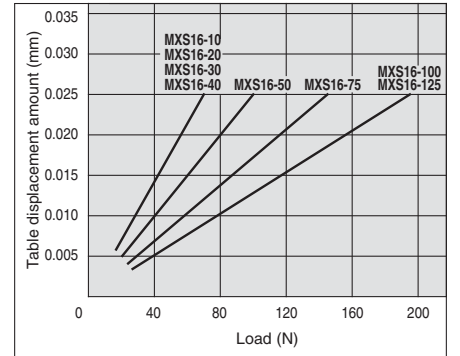


**Table displacement due to roll moment load**

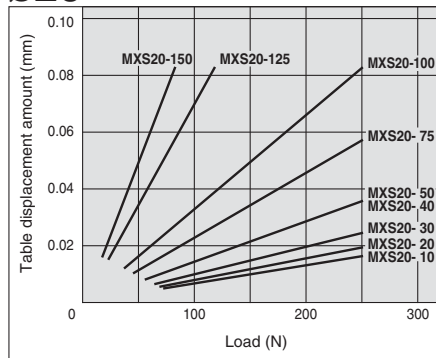
Displacement at "A" when a load is applied to "F" with the slide table retracted.



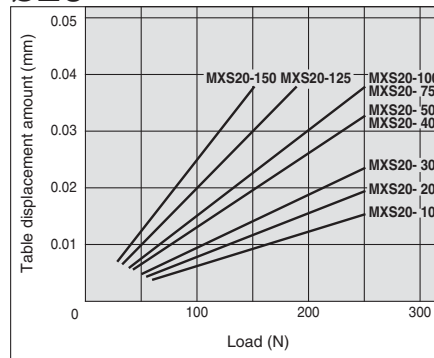
**ø16**



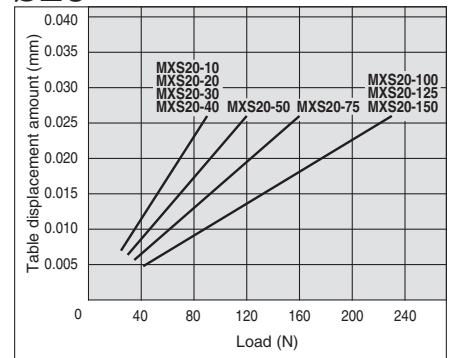
**ø20**



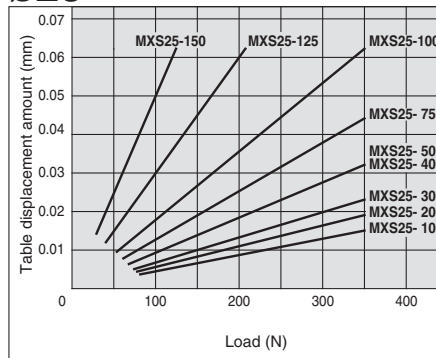
**ø20**



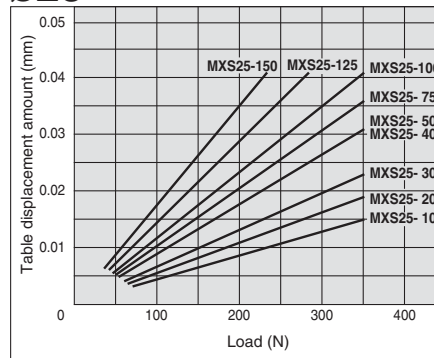
**ø20**



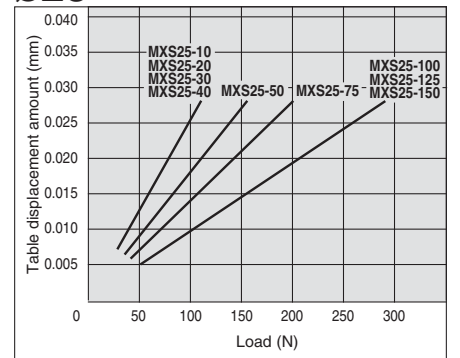
**ø25**



**ø25**



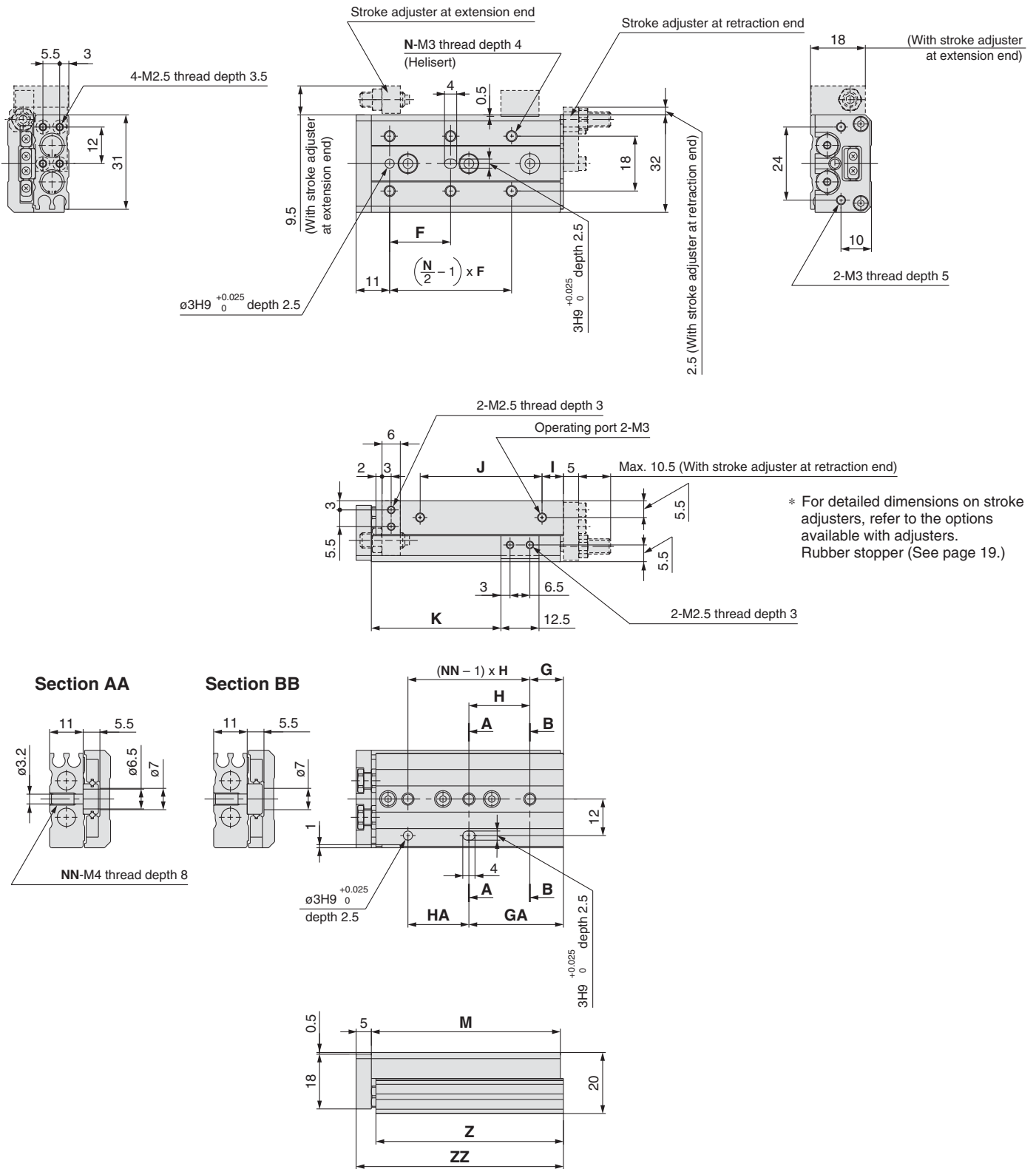
**ø25**



# Series MXS

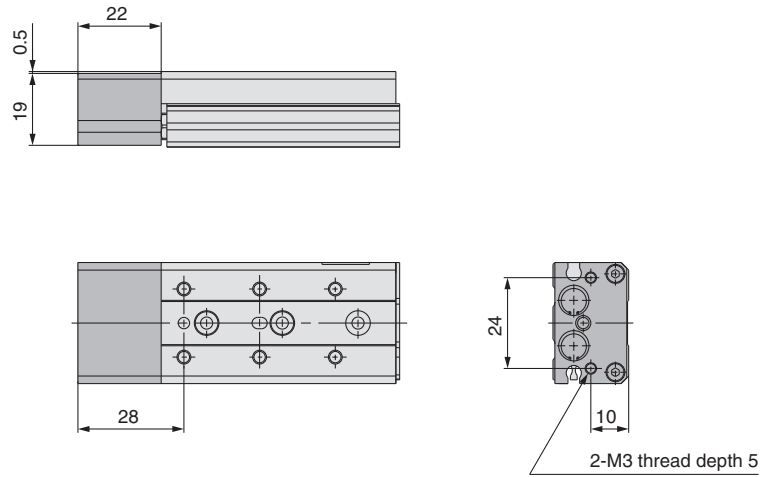
## Dimensions: MXS6

### Basic style



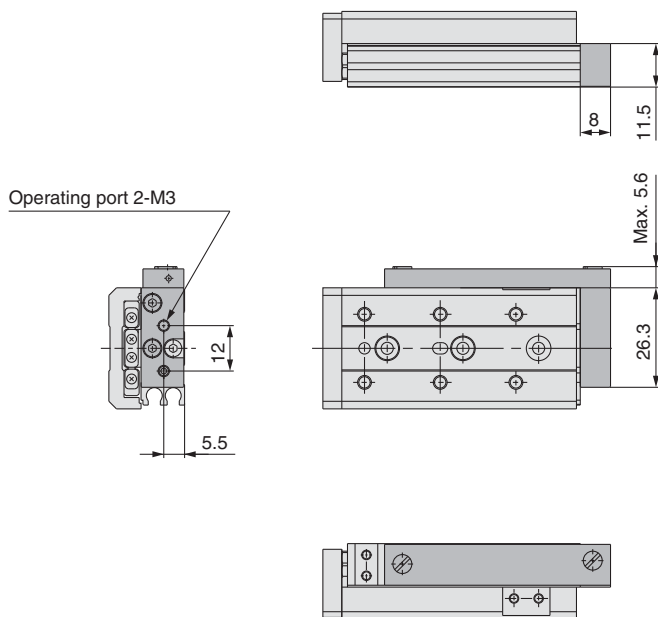
Model	F	N	G	H	NN	GA	HA	I	J	K	M	Z	ZZ
MXS6-10	20	4	6	25	2	11	20	10	17	22.5	42	41.5	48
MXS6-20	30	4	6	35	2	21	20	10	27	32.5	52	51.5	58
MXS6-30	20	6	11	20	3	31	20	7	40	42.5	62	61.5	68
MXS6-40	28	6	13	30	3	43	30	19	50	52.5	84	83.5	90
MXS6-50	38	6	17	24	4	41	48	25	60	62.5	100	99.5	106

**With buffer (ø6) MXS6-□□F**



\* Other dimensions are the same as the basic style.

**Axial piping type (ø6) MXS6-□□P**

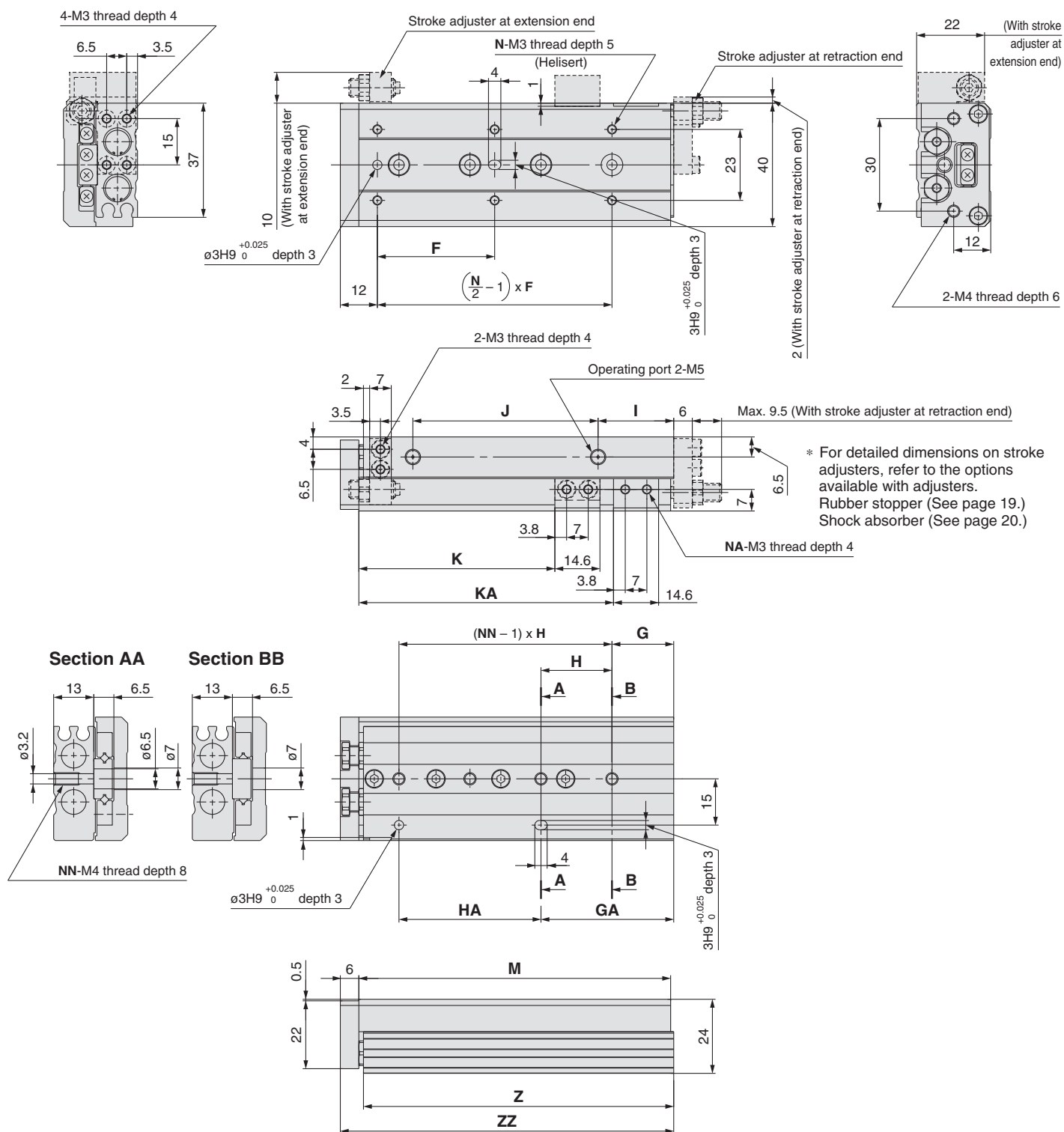


\* Other dimensions are the same as the basic style.

# Series MXS

## Dimensions: MXS8

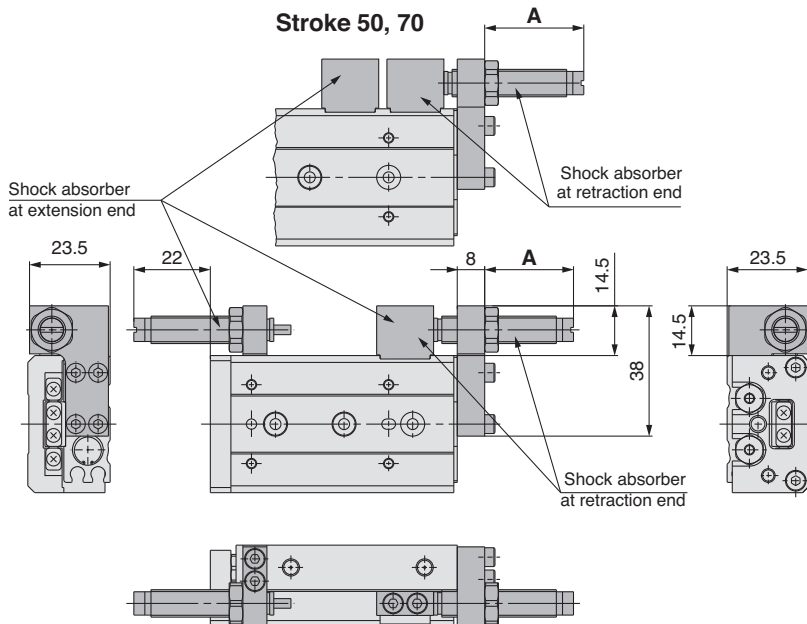
### Basic style



Model	F	N	G	H	NN	GA	HA	I	J	K	KA	NA	M	Z	ZZ
MXS8-10	25	4	9	28	2	17	20	13	19.5	23.5	—	2	49	48.5	56
MXS8-20	25	4	12	30	2	12	30	8.5	29	33.5	—	2	54	53.5	61
MXS8-30	40	4	13	20	3	33	20	9.5	39	43.5	—	2	65	64.5	72
MXS8-40	50	4	15	28	3	43	28	10.5	56	53.5	—	2	83	82.5	90
MXS8-50	38	6	20	23	4	43	46	24.5	60	63.5	82.5	4	101	100.5	108
MXS8-75	50	6	27	28	5	83	56	38.5	96	88.5	132.5	4	151	150.5	158

(mm)

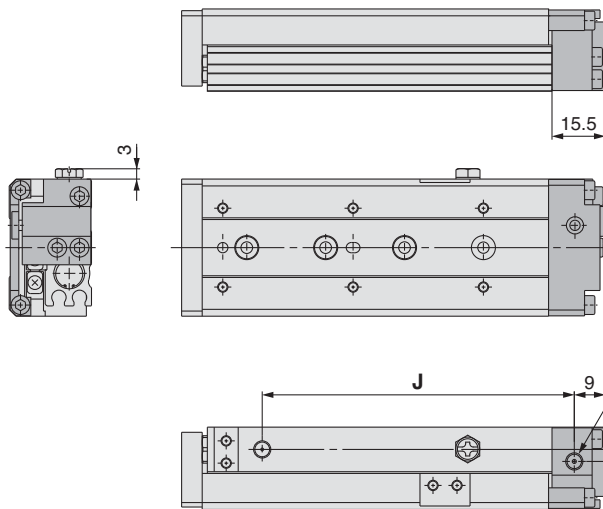
**With shock absorber (ø8) MXS8-□□BS/BT/B**



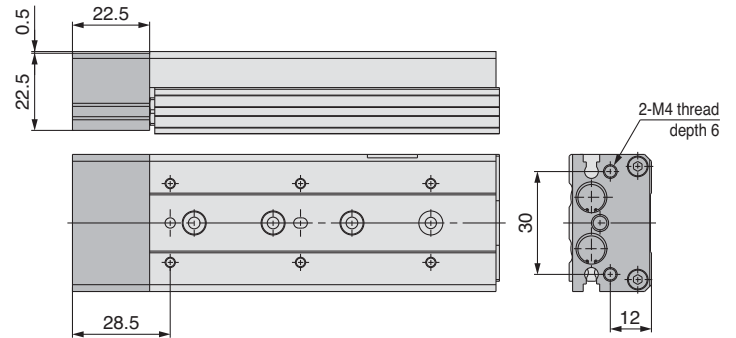
Model	Stroke adjustment range		A dimension (Retracted side mounting)
	Extension end	Retraction end	
MXS8-10	Maximum 20	5	22
MXS8-20		15	27
MXS8-30		15	26
MXS8-40		5	18
MXS8-50		20	29
MXS8-75		20	29

\* Other dimensions are the same as the basic style.

**With end lock (ø8) MXS8-□□R**



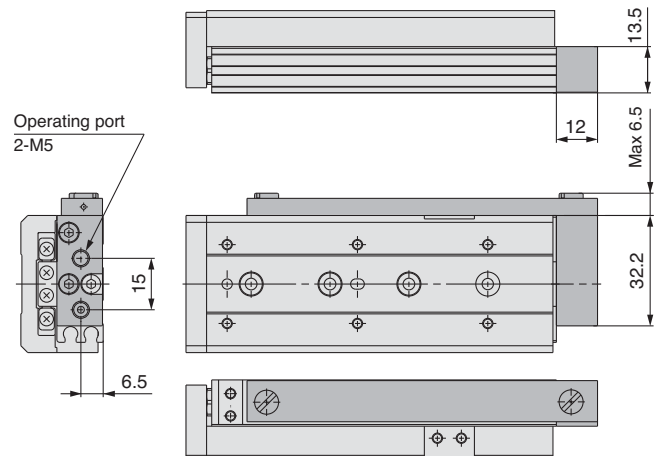
**With buffer (ø8) MXS8-□□F**



Operating port 2-M5

\* Other dimensions are the same as the basic style.

**Axial piping type (ø8) MXS8-□□P**



\* Other dimensions are the same as the basic style.

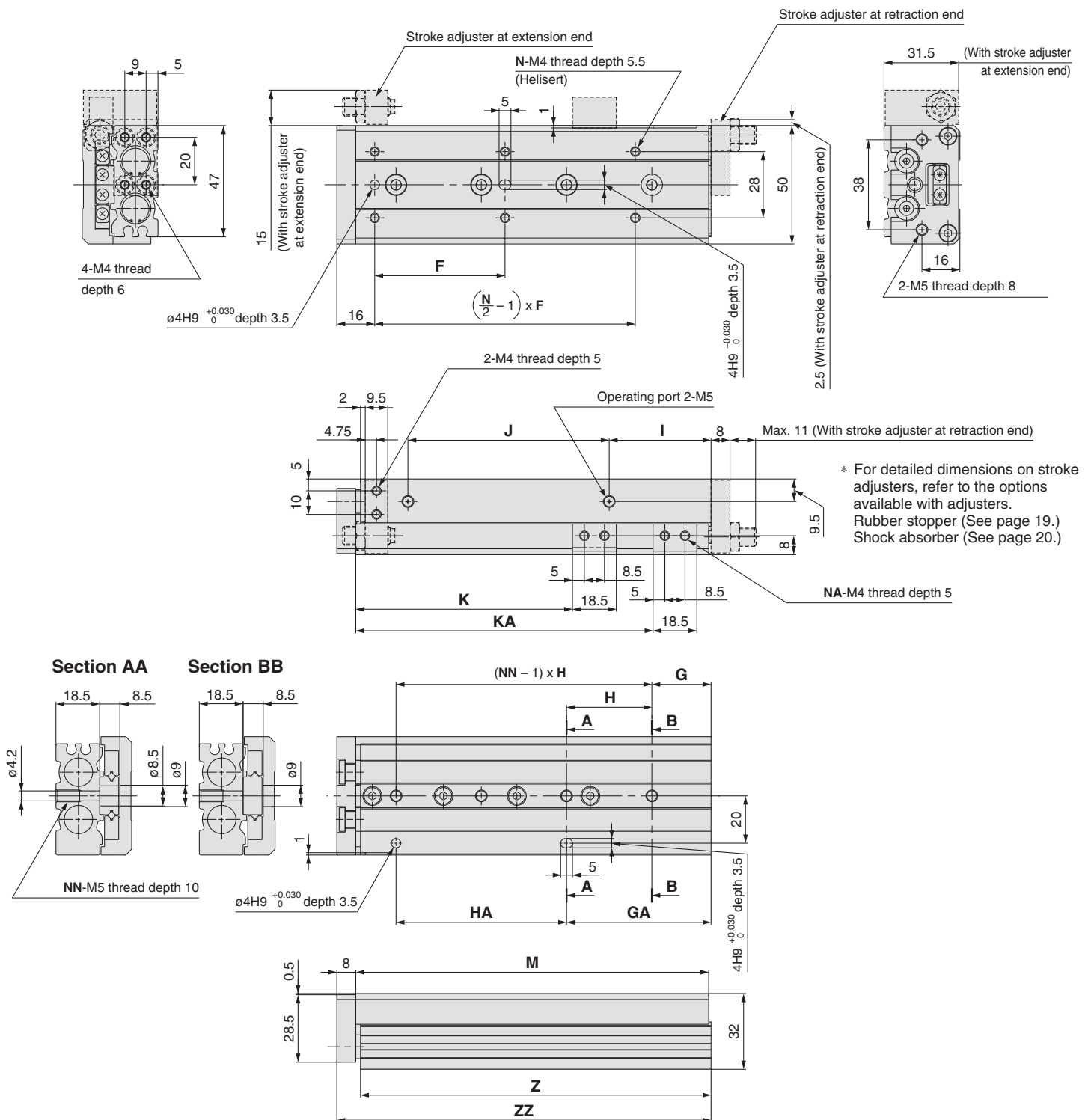
Model	J (mm)
MXS8-10R	39
MXS8-20R	44
MXS8-30R	55
MXS8-40R	73
MXS8-50R	91
MXS8-75R	141

\* Other dimensions are the same as the basic style.

# Series MXS

## Dimensions: MXS12

### Basic style

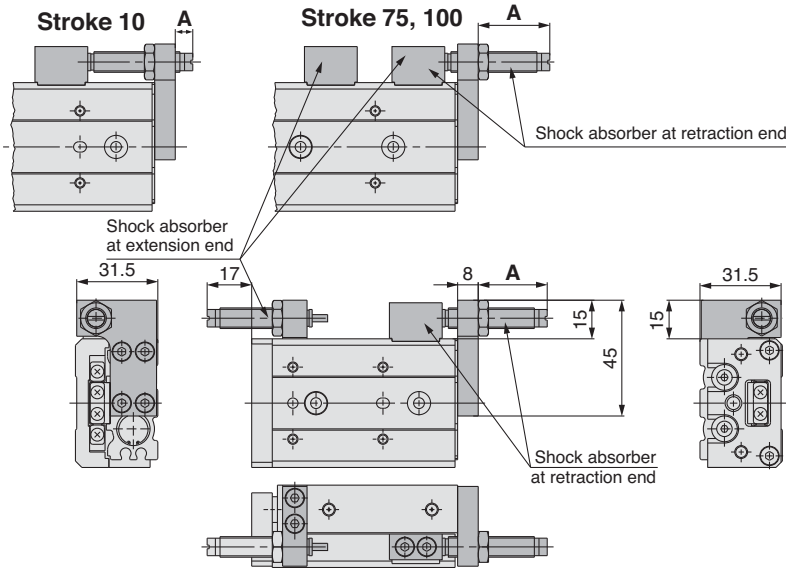


\* For detailed dimensions on stroke adjusters, refer to the options available with adjusters.  
 Rubber stopper (See page 19.)  
 Shock absorber (See page 20.)

(mm)

Model	F	N	G	H	NN	GA	HA	I	J	K	KA	NA	M	Z	ZZ
MXS12-10	35	4	15	40	2	15	40	10	40	26.5	—	2	71	70	80
MXS12-20	35	4	15	40	2	15	40	10	40	36.5	—	2	71	70	80
MXS12-30	35	4	15	40	2	15	40	10	40	46.5	—	2	71	70	80
MXS12-40	50	4	17	25	3	42	25	10	52	56.5	—	2	83	82	92
MXS12-50	35	6	15	36	3	51	36	22	60	66.5	—	2	103	102	112
MXS12-75	55	6	25	36	4	61	72	43	85	91.5	125.5	4	149	148	158
MXS12-100	65	6	35	38	5	111	76	52	130	116.5	179.5	4	203	202	212

**With shock absorber (ø12) MXS12-□□BS/BT/B**

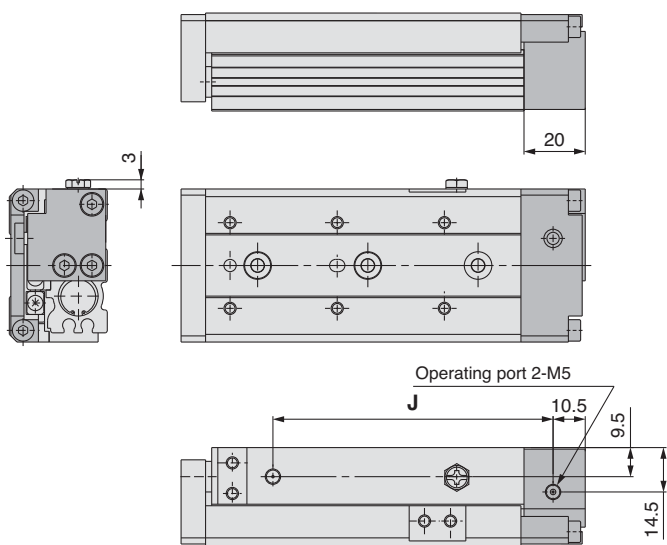


\* Other dimensions are the same as the basic style.

Model	Stroke adjustment range		A dimension (Retracted side mounting)
	Extension end	Retraction end	
<b>MXS12-10</b>	Maximum 20	2	7
<b>MXS12-20</b>		5	17
<b>MXS12-30</b>		15	27
<b>MXS12-40</b>		15	25
<b>MXS12-50</b>		5	15
<b>MXS12-75</b>		15	28
<b>MXS12-100</b>	15	28	

(mm)

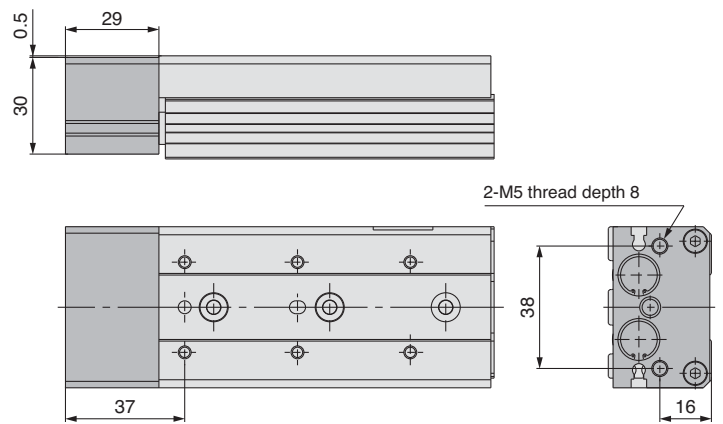
**With end lock (ø12) MXS12-□□R**



Model	J (mm)
<b>MXS12-10R</b>	59.5
<b>MXS12-20R</b>	59.5
<b>MXS12-30R</b>	59.5
<b>MXS12-40R</b>	71.5
<b>MXS12-50R</b>	91.5
<b>MXS12-75R</b>	137.5
<b>MXS12-100R</b>	191.5

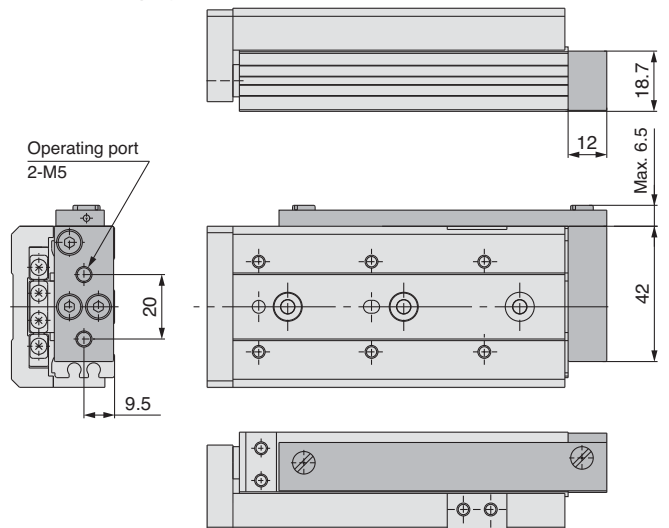
\* Other dimensions are the same as the basic style.

**With buffer (ø12) MXS12-□□F**



\* Other dimensions are the same as the basic style.

**Axial piping type (ø12) MXS12-□□P**

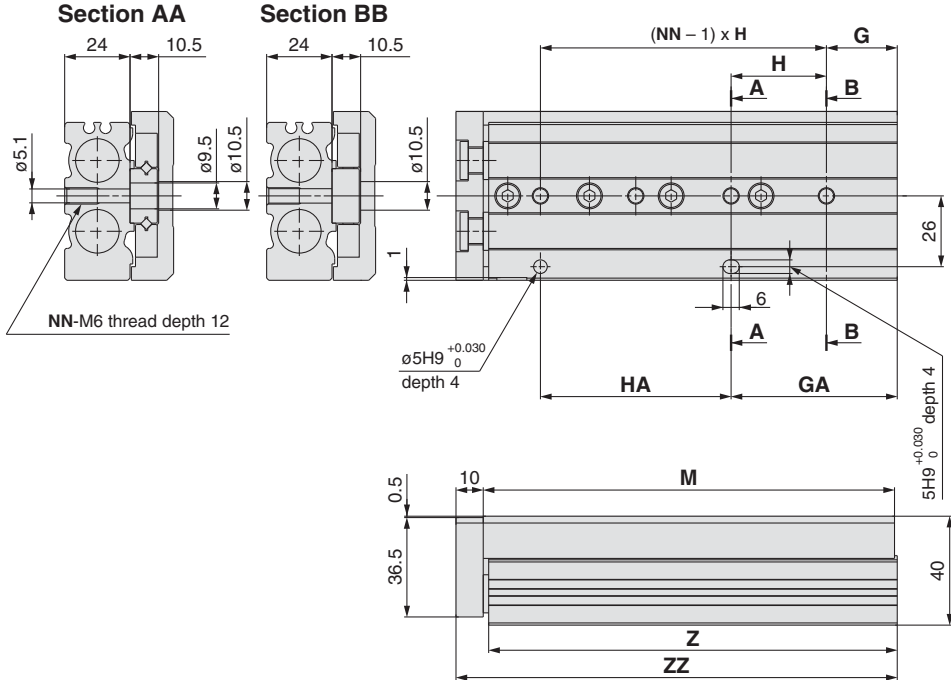
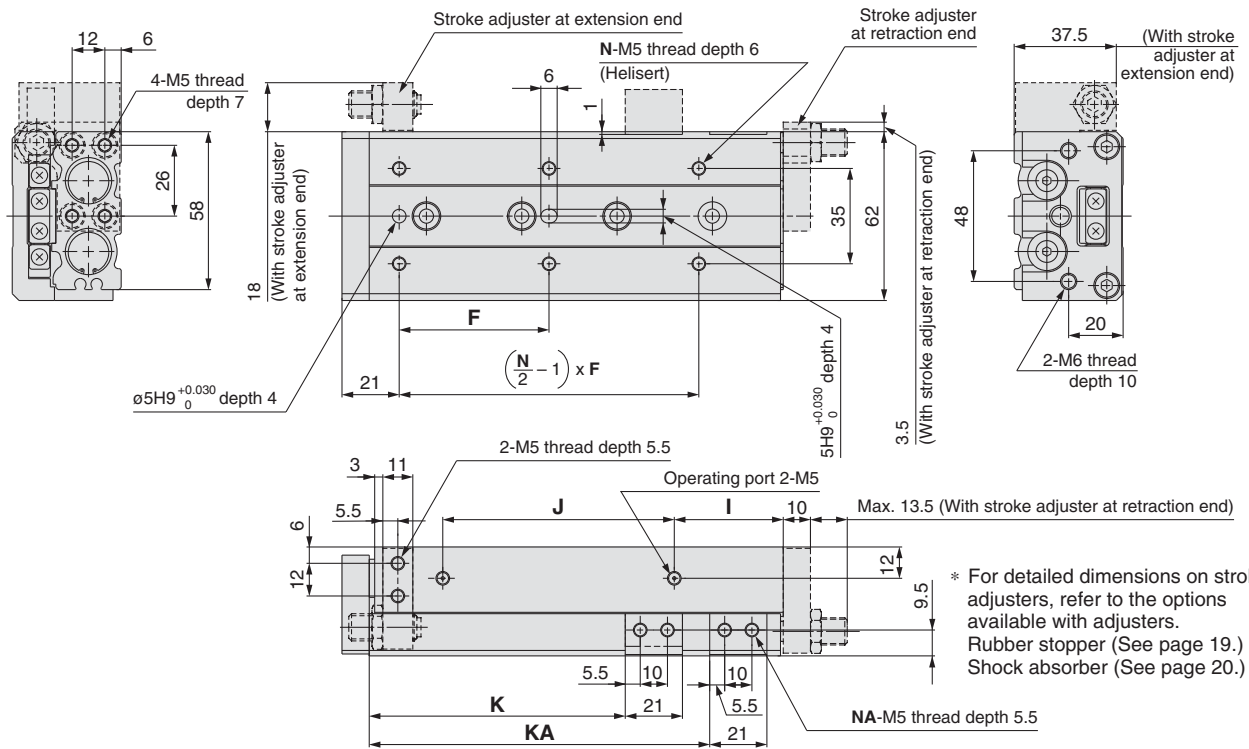


\* Other dimensions are the same as the basic style.

# Series MXS

## Dimensions: MXS16

### Basic style

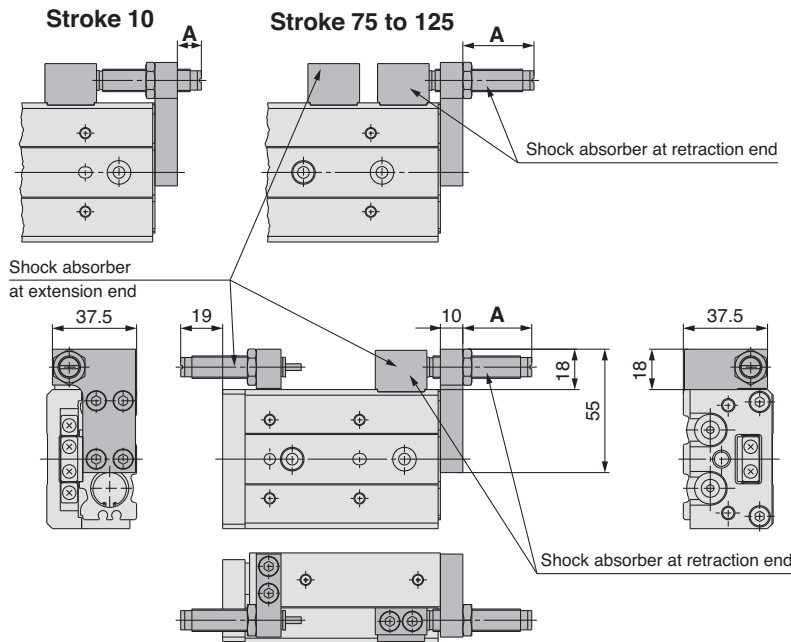


(mm)

Model	F	N	G	H	NN	GA	HA	I	J	K	KA	NA	M	Z	ZZ
MXS16-10	35	4	16	40	2	16	40	10	40	29	—	2	76	75	87
MXS16-20	35	4	16	40	2	16	40	10	40	39	—	2	76	75	87
MXS16-30	35	4	16	40	2	16	40	10	40	49	—	2	76	75	87
MXS16-40	40	4	16	50	2	16	50	10	50	59	—	2	86	85	97
MXS16-50	30	6	21	30	3	51	30	15	60	69	—	2	101	100	112
MXS16-75	55	6	26	35	4	61	70	40	85	94	125	4	151	150	162
MXS16-100	65	6	39	35	5	109	70	55	118	119	173	4	199	198	210
MXS16-125	70	8	19	35	7	159	70	68	155	144	223	4	249	248	260



**With shock absorber (ø16) MXS16-□□BS/BT/B**

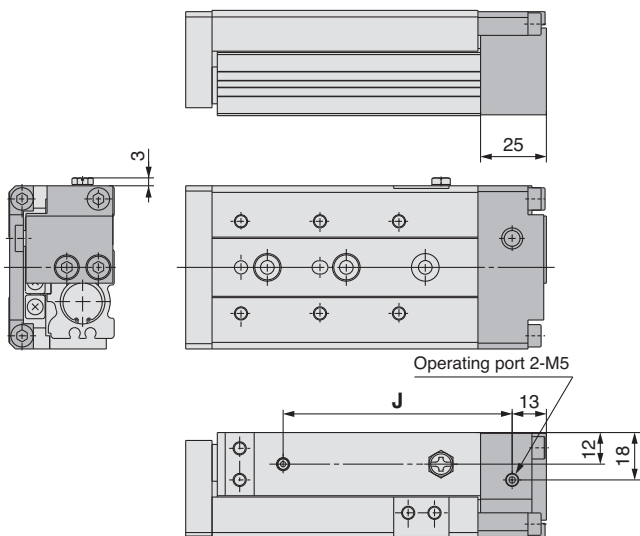


(mm)

Model	Stroke adjustment range		A dimension (Retracted side mounting)
	Extension end	Retraction end	
<b>MXS16-10</b>	Maximum 25	5	11
<b>MXS16-20</b>		10	21
<b>MXS16-30</b>		20	31
<b>MXS16-40</b>		20	31
<b>MXS16-50</b>		15	26
<b>MXS16-75</b>		20	32
<b>MXS16-100</b>		20	32
<b>MXS16-125</b>		20	32

\* Other dimensions are the same as the basic style.

**With end lock (ø16) MXS16-□□R**

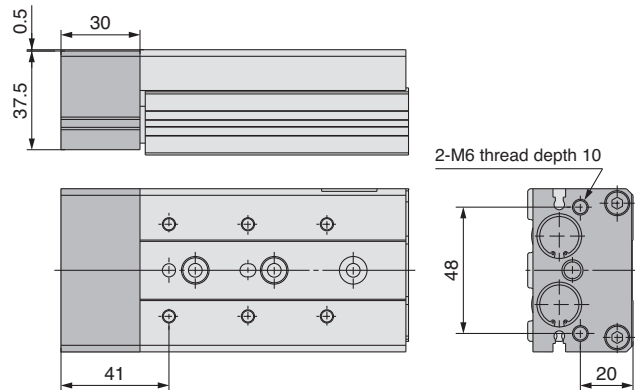


(mm)

Model	J
<b>MXS16-10R</b>	62
<b>MXS16-20R</b>	62
<b>MXS16-30R</b>	62
<b>MXS16-40R</b>	72
<b>MXS16-50R</b>	87
<b>MXS16-75R</b>	137
<b>MXS16-100R</b>	185
<b>MXS16-125R</b>	235

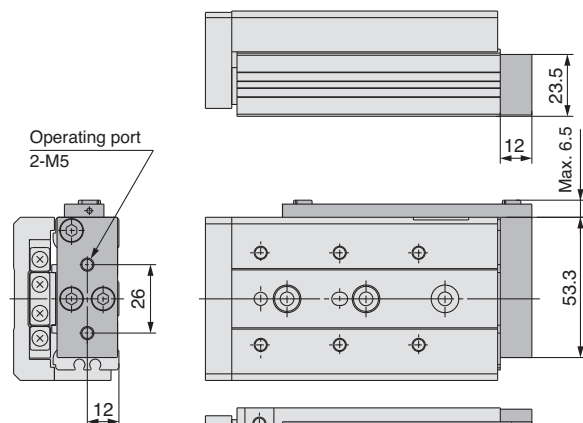
\* Other dimensions are the same as the basic style.

**With buffer (ø16) MXS16-□□F**



\* Other dimensions are the same as the basic style.

**Axial piping type (ø16) MXS16-□□P**

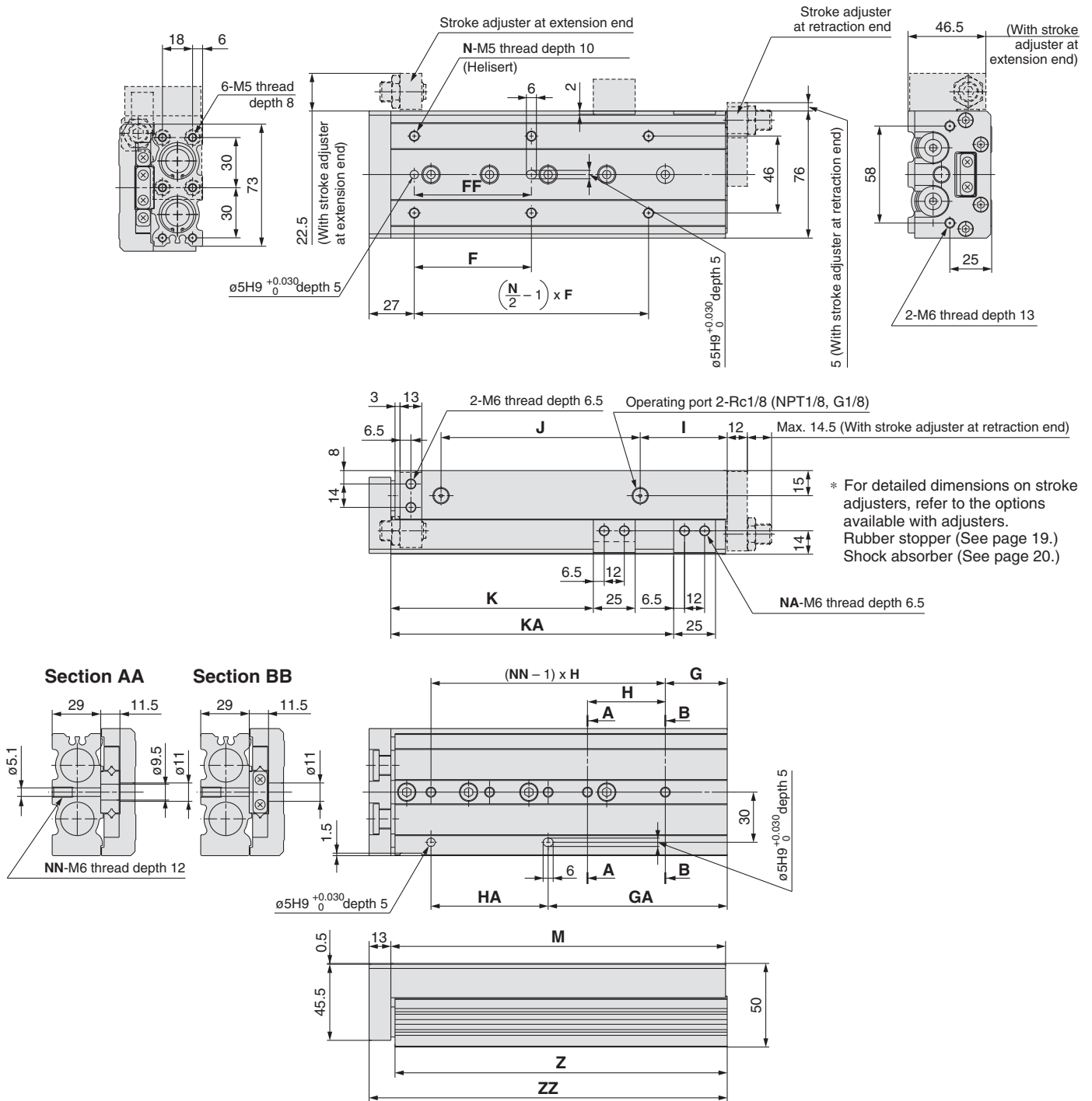


\* Other dimensions are the same as the basic style.

# Series MXS

## Dimensions: MXS20

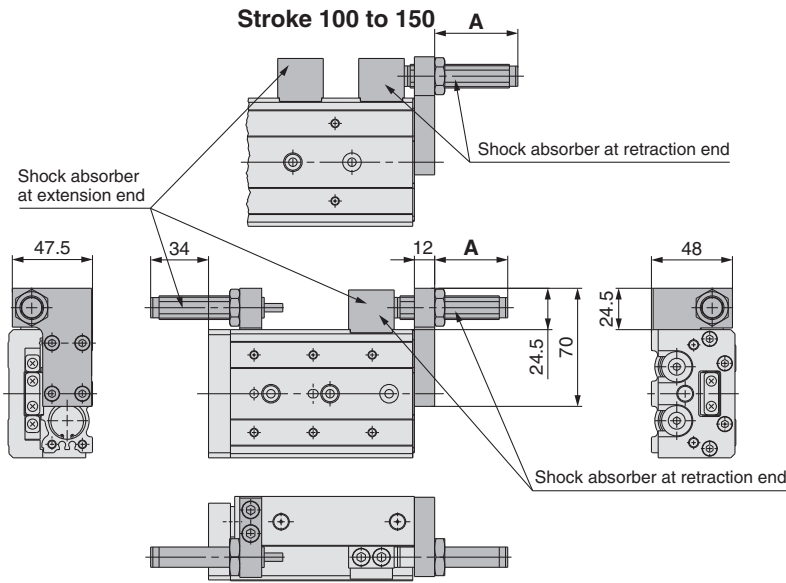
### Basic style



\* For detailed dimensions on stroke adjusters, refer to the options available with adjusters.  
 Rubber stopper (See page 19.)  
 Shock absorber (See page 20.)

Model	F	FF	N	G	H	NN	GA	HA	I	J	K	KA	NA	M	Z	ZZ
MXS20-10	50	40	4	15	45	2	25	35	10	44	31	—	2	83	81.5	97
MXS20-20	50	40	4	15	45	2	25	35	10	44	41	—	2	83	81.5	97
MXS20-30	50	40	4	15	45	2	25	35	10	44	51	—	2	83	81.5	97
MXS20-40	60	50	4	15	55	2	35	35	10	54	61	—	2	93	91.5	107
MXS20-50	35	35	6	15	35	3	50	35	10	69	71	—	2	108	106.5	122
MXS20-75	60	60	6	19	35	4	54	70	10	108	96	—	2	147	145.5	161
MXS20-100	70	70	6	37	35	5	107	70	58	113	121	169	4	200	198.5	214
MXS20-125	70	70	8	41	38	6	155	76	70	155	146	223	4	254	252.5	268
MXS20-150	80	80	8	19	44	7	195	88	87	190	171	275	4	306	304.5	320

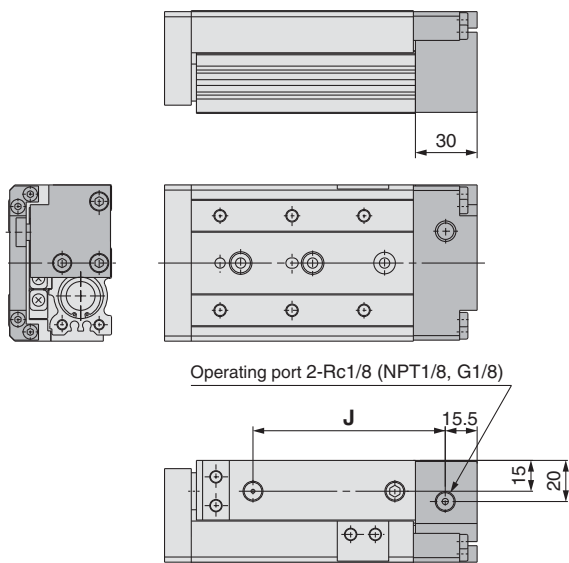
**With shock absorber (ø20) MXS20-□□BS/BT/B**



Model	Stroke adjustment range		A dimension (Retracted side mounting)
	Extension end	Retraction end	
MXS20-10	Maximum 40	5	28
MXS20-20		15	38
MXS20-30		25	48
MXS20-40		35	48
MXS20-50		30	43
MXS20-75		15	29
MXS20-100		35	49
MXS20-125		35	49
MXS20-150		35	49

\* Other dimensions are the same as the basic style.

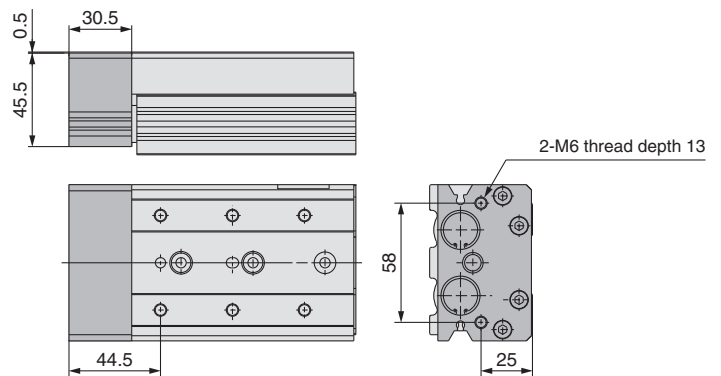
**With end lock (ø20) MXS20-□□R**



Model	J
MXS20-10R	68.5
MXS20-20R	68.5
MXS20-30R	68.5
MXS20-40R	78.5
MXS20-50R	93.5
MXS20-75R	132.5
MXS20-100R	185.5
MXS20-125R	239.5
MXS20-150R	291.5

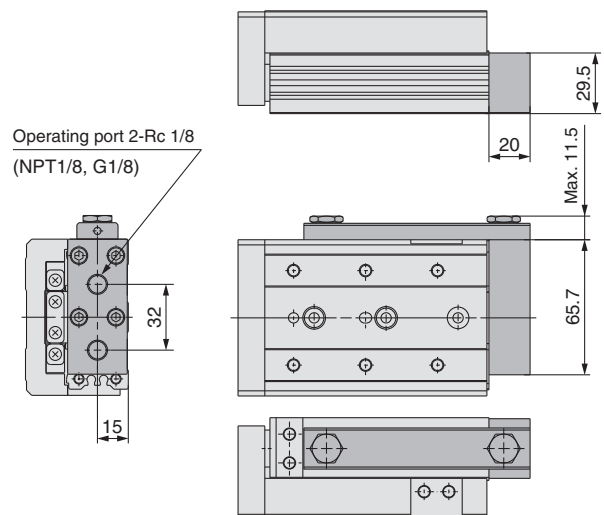
\* Other dimensions are the same as the basic style.

**With buffer (ø20) MXS20-□□F**



\* Other dimensions are the same as the basic style.

**Axial piping type (ø20) MXS20-□□P**

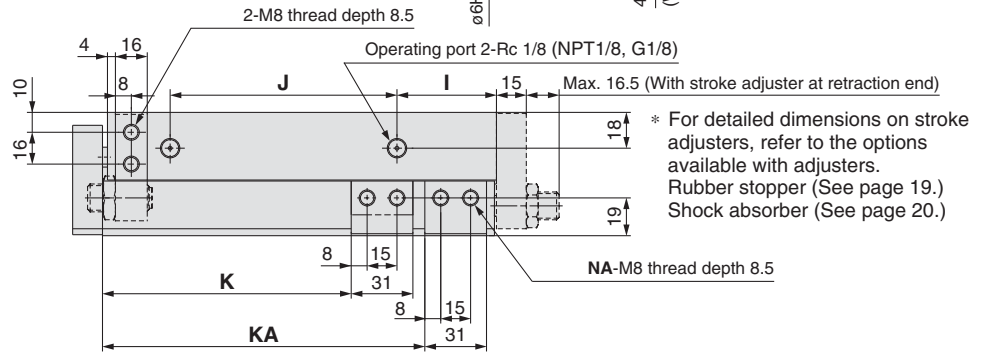
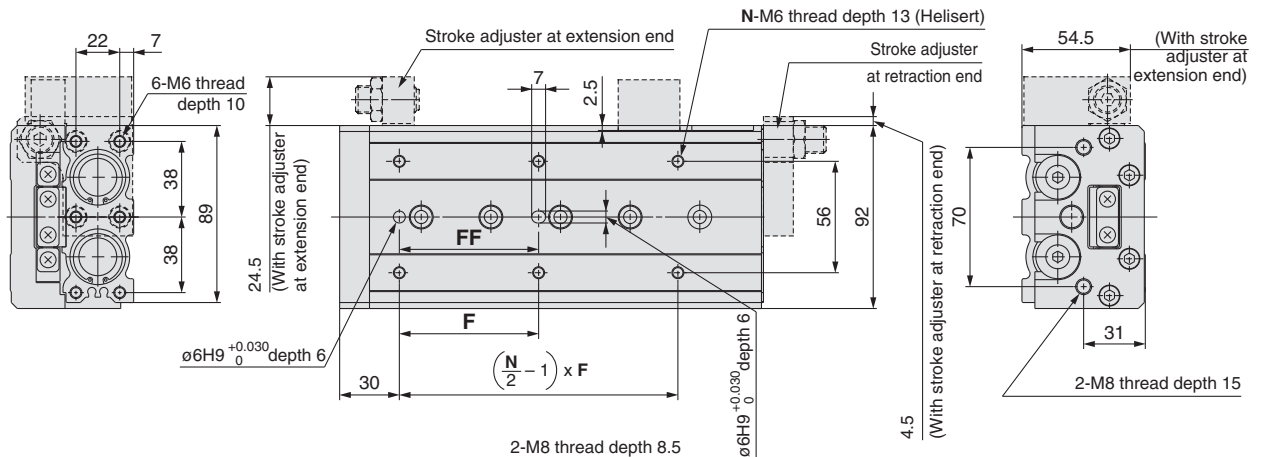


\* Other dimensions are the same as the basic style.

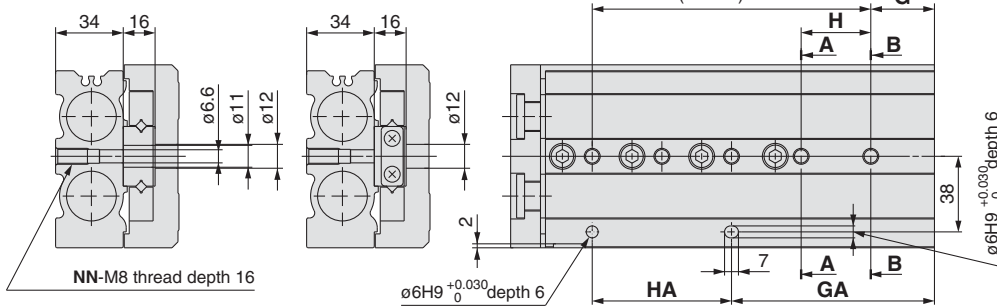
# Series MXS

## Dimensions: MXS25

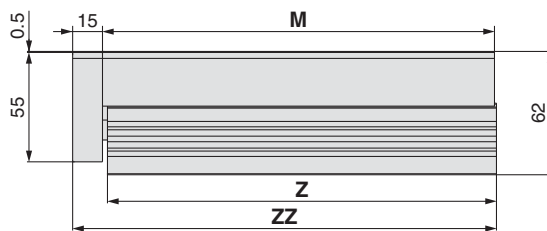
### Basic style



### Section AA

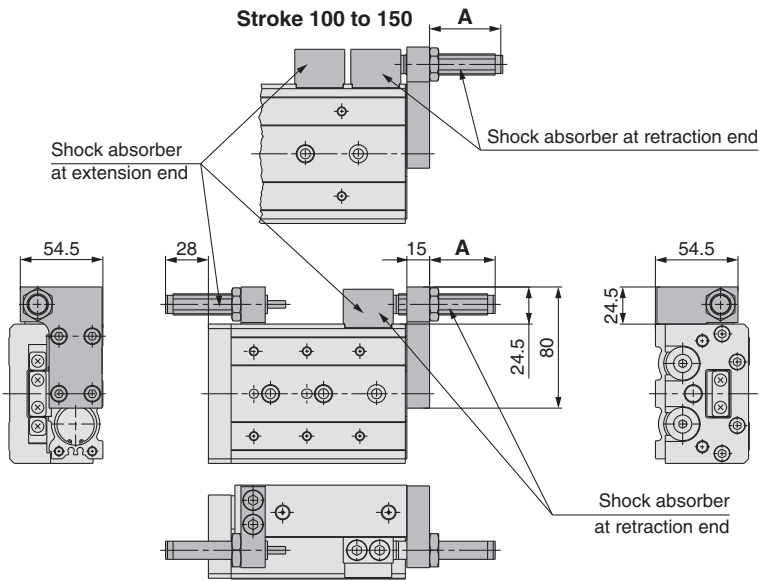


### Section BB



Model	F	FF	N	G	H	NN	GA	HA	I	J	K	KA	NA	M	Z	ZZ
MXS25-10	50	40	4	22	45	2	22	45	12	47	35	—	2	92	90.5	108
MXS25-20	50	40	4	22	45	2	22	45	12	47	45	—	2	92	90.5	108
MXS25-30	50	40	4	22	45	2	22	45	12	47	55	—	2	92	90.5	108
MXS25-40	60	50	4	22	55	2	22	55	12	57	65	—	2	102	100.5	118
MXS25-50	35	35	6	20	35	3	55	35	12	70	75	—	2	115	113.5	131
MXS25-75	60	60	6	26	35	4	61	70	33	90	100	—	2	156	154.5	172
MXS25-100	70	70	6	32	35	5	102	70	50	114	125	162	4	197	195.5	213
MXS25-125	75	75	8	40	38	6	154	76	67	155	150	218	4	255	253.5	271
MXS25-150	80	80	8	30	40	7	190	80	82	180	175	258	4	295	293.5	311

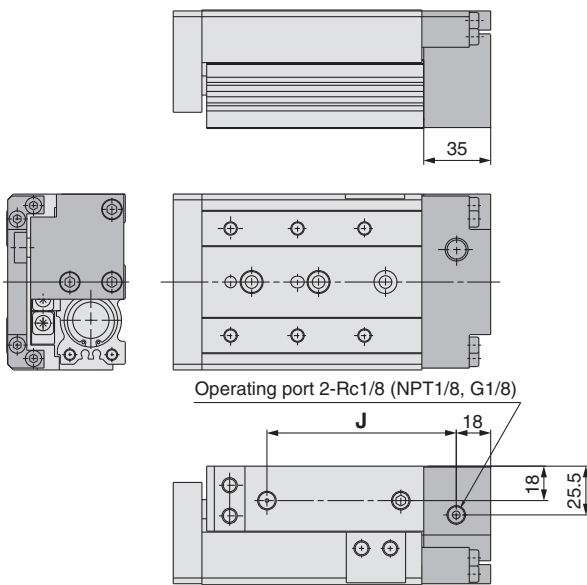
**With shock absorber (ø25) MXS25-□□BS/BT/B**



Model	Stroke adjustment range		A dimension (Retracted side mounting)
	Extension end	Retraction end	
MXS25-10	Maximum 35	5	26
MXS25-20		15	36
MXS25-30		25	46
MXS25-40		35	46
MXS25-50		30	43
MXS25-75		15	27
MXS25-100		35	48
MXS25-125		35	46
MXS25-150		35	46

\* Other dimensions are the same as the basic style.

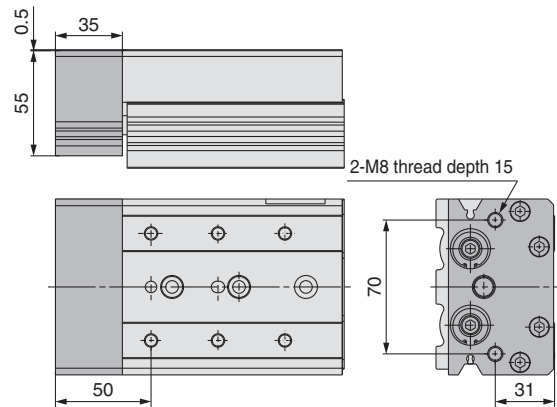
**With end lock (ø25) MXS25-□□R**



Model	J (mm)
MXS25-10R	76
MXS25-20R	76
MXS25-30R	76
MXS25-40R	86
MXS25-50R	99
MXS25-75R	140
MXS25-100R	181
MXS25-125R	239
MXS25-150R	279

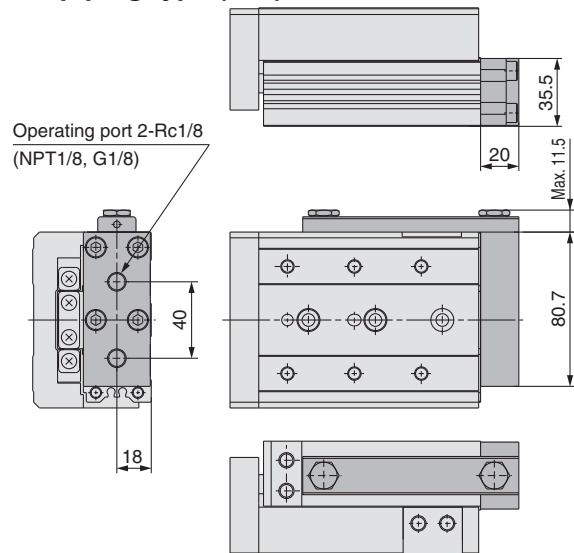
\* Other dimensions are the same as the basic style.

**With buffer (ø25) MXS25-□□F**



\* Other dimensions are the same as the basic style.

**Axial piping type (ø25) MXS25-□□P**



\* Other dimensions are the same as the basic style.

# Series MXS Optional Specifications 1

## Dimensions of Stroke Adjuster at Extension End

**Body mounting section**

**Table mounting section**

Applicable size	Model	Stroke adjustment range (mm)	Body mounting section								Table mounting section			
			A	B	C	D	E	F	M	P*	H	I	J	Q*
MXS6 (L)	MXS-AS6 (L)	5	6	17.8	10.5	16.5	7	2.5	M5	M2.5 x 10	12.5	6	8.5	M2.5 x 8
	MXS-AS6 (L)-X11	26.5												
MXS8 (L)	MXS-AS8 (L)	5	7	21.5	11	16.5	8	3	M6	M3 x 12	14.6	7	10	M3 x 10
	MXS-AS8 (L)-X11	26.5												
	MXS-AS8 (L)-X12	36.5												
MXS12 (L)	MXS-AS12 (L)	5	9.5	31	16	20	12	4	M8 x 1	M4 x 15	18.5	10	13	M4 x 12
	MXS-AS12 (L)-X11	30												
	MXS-AS12 (L)-X12	40												
MXS16 (L)	MXS-AS16 (L)	5	11	37	19	24.5	14	5	M10 x 1	M5 x 18	21	12	16.5	M5 x 18
	MXS-AS16 (L)-X11	34.5												
	MXS-AS16 (L)-X12	44.5												
MXS20 (L)	MXS-AS20 (L)	5	13	45.5	24	27.5	17	6	M12 x 1.25	M6 x 20	25	13	21	M6 x 20
	MXS-AS20 (L)-X11	37.5												
	MXS-AS20 (L)-X12	47.5												
MXS25 (L)	MXS-AS25 (L)	5	16	53.5	26.5	32.5	19	6	M14 x 1.5	M8 x 25	31	17	25.5	M8 x 25
	MXS-AS25 (L)-X12	52.5												

\* Size of hexagon socket head cap screw

It is also available with the symmetric type. For ordering part numbers, refer to "How to Order Stroke Adjuster" below. Dimensions are identical with the standard

## Dimensions of Stroke Adjuster at Retraction End

\* For MXS6, MXS8

Applicable size	Model	Stroke adjustment range (mm)	A	B	C	D	E	F	G	H	J*	K
MXS6 (L)	MXS-AT6 (L)	5	21	19	10.5	8	16.5	5	7	2.5	M2.5 x 8	M5 x 0.8
	MXS-AT6 (L)-X11	15					26.5					
MXS8 (L)	MXS-AT8 (L)	5	25	22.5	12.5	9	16.5	6	8	3	M3 x 10	M6 x 1
	MXS-AT8 (L)-X11	15					26.5					
	MXS-AT8 (L)-X12	25					36.5					
MXS12 (L)	MXS-AT12 (L)	5	32	31	18.5	13	20	8	12	4	M4 x 8	M8 x 1
	MXS-AT12 (L)-X11	15					30					
	MXS-AT12 (L)-X12	25					40					
MXS16 (L)	MXS-AT16 (L)	5	40	38.5	23	15	24.5	10	14	5	M5 x 10	M10 x 1
	MXS-AT16 (L)-X11	15					34.5					
	MXS-AT16 (L)-X12	25					44.5					
MXS20 (L)	MXS-AT20 (L)	5	50	48	29	21	27.5	12	17	6	M5 x 12	M12 x 1.25
	MXS-AT20 (L)-X11	15					37.5					
	MXS-AT20 (L)-X12	25					47.5					
MXS25 (L)	MXS-AT25 (L)	5	60	58	35	23	32.5	15	19	6	M6 x 16	M14 x 1.5
	MXS-AT25 (L)-X11	15					42.5					
	MXS-AT25 (L)-X12	25					52.5					

\* Size of hexagon socket head cap screw

It is also available with the symmetric type. For ordering part numbers, refer to "How to Order Stroke Adjuster" below. Dimensions are identical with the standard

## How to Order Stroke Adjuster (Accessory)

MXS — AS 12 L — X11

**Stroke adjuster**

AS	Stroke adjuster	Extension end
AT	Stroke adjuster	Retraction end
BS	Shock absorber	Extension end
BT	Shock absorber	Retraction end

**Symmetric type**

-	Standard type
L	Symmetric type

**Adjustable range (Stroke adjuster only)**

-	5 mm	Standard
-X11	15 mm	Option
-X12	25 mm	

**Applicable bore size (mm)**

6	ø6
8	ø8
12	ø12
16	ø16
20	ø20
25	ø25

### Adjustable range (Stroke adjuster only)

-	5 mm	Standard
-X11	15 mm	Option
-X12	25 mm	

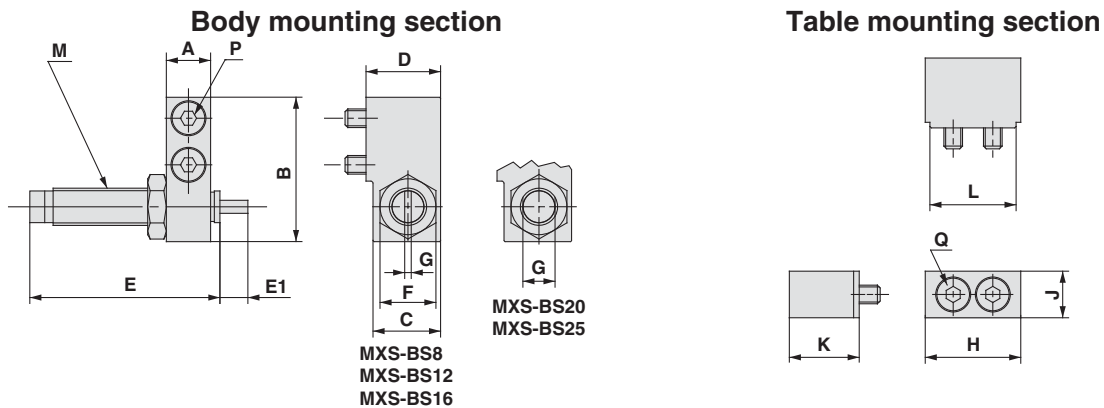
\* -X12 (adjustable range: 25 mm) is not available with the MXS6 series.

\* -X11 and -X12 are not available with shock absorber type.

\* W/ shock absorber is not available with the MXS6 series.

\* For dimensions, refer to the figure above. As for symmetric type, view the external dimensions symmetrically. (Adjusting bolt in symmetric type is equipped in reverse direction.)

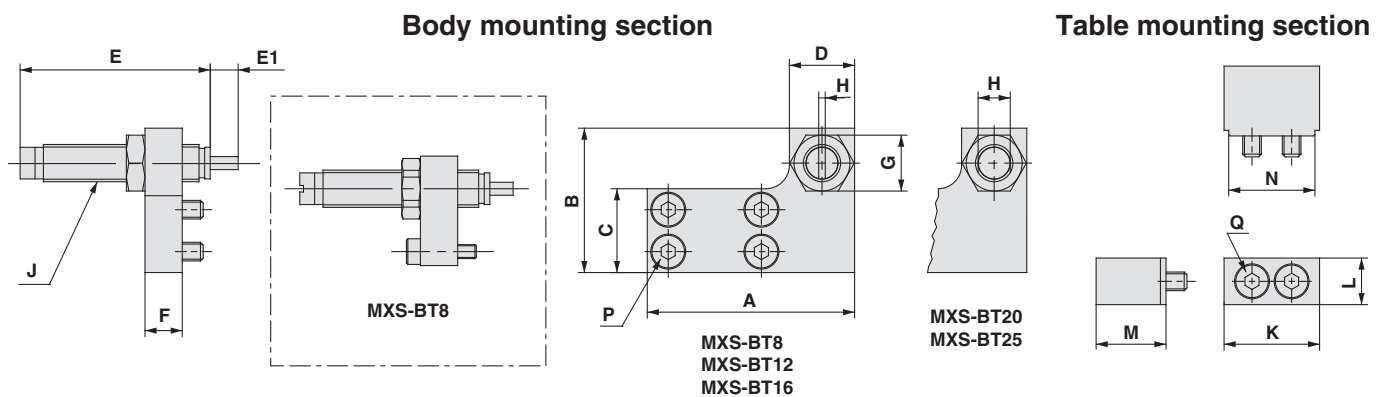
**Dimensions of Adjuster Option/With Shock Absorber (BS/BT)**  
**Extension End**



Applicable size	Model	Body mounting section										Table mounting section				
		A	B	C	D	E	E1	F	G	M	P*	H	J	K	L	Q*
<b>MXS8 (L)</b>	MXS-BS8 (L)	7	23	14	15.5	40.8	5	12	1.4	M8 x 1	M3 x 16	16.6	7	15.5	14.6	M3 x 16
<b>MXS12 (L)</b>	MXS-BS12 (L)	9.5	31	14.5	16	40.8	6	12	1.4	M8 x 1	M4 x 15	20.5	10	15	18.5	M4 x 15
<b>MXS16 (L)</b>	MXS-BS16 (L)	11	37	17.5	19	46.7	7	14	1.4	M10 x 1	M5 x 18	23	12	18.5	21	M5 x 18
<b>MXS20 (L)</b>	MXS-BS20 (L)	13	47	23.5	26	67.3	11	19	12	M14 x 1.5	M6 x 25	27	13	25.5	25	M6 x 25
<b>MXS25 (L)</b>	MXS-BS25 (L)	16	53.5	23.5	26.5	67.3	12	19	12	M14 x 1.5	M8 x 25	33	17	25.5	31	M8 x 25

\* Size of hexagon socket head cap screw  
 It is also available with the symmetric type. For ordering part numbers, refer to "How to Order Stroke Adjuster" on page 19. Dimensions are identical with the standard type.

**Retraction End**

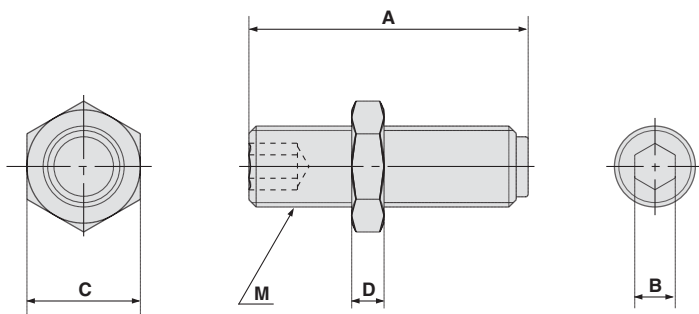


Applicable size	Model	Body mounting section										Table mounting section					
		A	B	C	D	E	E1	F	G	H	J	P*	K	L	M	N	Q*
<b>MXS8 (L)</b>	MXS-BT8 (L)	38	23	12.5	14	40.8	5	8	12	1.4	M8 x 1	M3 x 12	16.6	7	15.5	14.6	M3 x 16
<b>MXS12 (L)</b>	MXS-BT12 (L)	45	31	18	14	40.8	6	8	12	1.4	M8 x 1	M4 x 8	20.5	10	15	18.5	M4 x 15
<b>MXS16 (L)</b>	MXS-BT16 (L)	55	37	23.5	16	46.7	7	10	14	1.4	M10 x 1	M5 x 10	23	12	18.5	21	M5 x 18
<b>MXS20 (L)</b>	MXS-BT20 (L)	70	47	29	23	67.3	11	12	19	12	M14 x 1.5	M5 x 12	27	13	25.5	25	M6 x 25
<b>MXS25 (L)</b>	MXS-BT25 (L)	80	54	35	23	67.3	12	15	19	12	M14 x 1.5	M6 x 16	33	17	25.5	31	M8 x 25

\* Size of hexagon socket head cap screw  
 It is also available with the symmetric type. For ordering part numbers, refer to "How to Order Stroke Adjuster" on page 19. Dimensions are identical with the standard type.

# Series MXS Optional Specifications 2

## Dimensions of Adjusting Bolt



Applicable size	Model	Stroke adjustment range (mm)	A	B	C	D	M
MXS6 (L)	MXS-A627	5	16.5	2.5	7	3	M5
	MXS-A627-X11	15	26.5				
MXS8 (L)	MXS-A827	5	16.5	3	8	3.5	M6
	MXS-A827-X11	15	26.5				
	MXS-A827-X12	25	36.5				
MXS12 (L)	MXS-A1227	5	20	4	12	4	M8 x 1
	MXS-A1227-X11	15	30				
	MXS-A1227-X12	25	40				
MXS16 (L)	MXS-A1627	5	24.5	5	14	4	M10 x 1
	MXS-A1627-X11	15	34.5				
	MXS-A1627-X12	25	44.5				
MXS20 (L)	MXS-A2027	5	27.5	6	17	5	M12 x 1.25
	MXS-A2027-X11	15	37.5				
	MXS-A2027-X12	25	47.5				
MXS25 (L)	MXS-A2527	5	32.5	6	19	6	M14 x 1.5
	MXS-A2527-X11	15	42.5				
	MXS-A2527-X12	25	52.5				

## How to Order Adjusting Bolt

MXS — A 12 27 — X11

Applicable bore size (mm) ●

MXS6	ø6
MXS8	ø8
MXS12	ø12
MXS16	ø16
MXS20	ø20
MXS25	ø25

● Adjustment range

-	5 mm
X11	15 mm
X12	25 mm

\* -X12 (adjustable range: 25 mm) is not available with the MXS6 series.

\* For dimensions, refer to the figure above.

\* Symmetric type is also the same.



## Shock Absorber Specifications

Shock absorber model	RB0805	RB0806	RB1007	RB1411	RB1412	
Applicable slide table	MXS8	MXS12	MXS16	MXS20	MXS25	
Maximum energy absorption (J)	0.98	2.94	5.88	14.7	19.6	
Stroke absorption (mm)	5	6	7	11	12	
Maximum collision speed (mm/s)	-10 to 60					
Maximum operating frequency (cycle/min)	80	80	70	45	45	
Maximum allowable thrust (N)	245	245	422	814	814	
Ambient temperature range (°C)	-10 to 60					
Spring force (N)	When extended	1.96	1.96	4.22	6.86	6.86
	When retracted	3.83	4.22	6.86	15.30	15.98
Weight (g)	15	15	25	65	65	

## With End Lock Specifications

Model	MXS8	MXS12	MXS16	MXS20	MXS25
Bore size (mm)	8	12	16	20	25
Piston speed	50 to 500 mm/s				
Holding force (N)	25	60	110	160	250

Note) For caution on end lock, refer to back page 4.

## With Buffer Mechanism Specifications

Model	MXS6	MXS8	MXS12	MXS16	MXS20	MXS25	
Bore size (mm)	6	8	12	16	20	25	
Piston speed	50 to 500 mm/s (Horizontal mounting 50 to 300 mm/s)						
Buffer stroke (mm)	5			10			
Buffer stroke load (N)	Stroke at 0 mm	3	5	10	13	17	21
	Maximum stroke	6	8	13	17	25	29

Note) For cautions on handling the buffer, refer to back page 4.  
 Note) If stroke is adjusted with the stroke adjuster at extension end, the buffer stroke is shortened by the adjusted length.

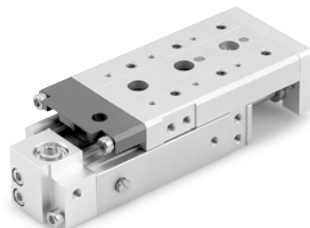
## Applicable Auto Switch for Buffer

Type	Model	Specifications	Electrical entry direction
Solid state switch	D-M9BV	With indicator light, 2-wire	Vertical
	D-M9NV	With indicator light, 3-wire, Output: NPN	
	D-M9PV	With indicator light, 3-wire, Output: PNP	

\* The auto switch for the buffer must be ordered separately.



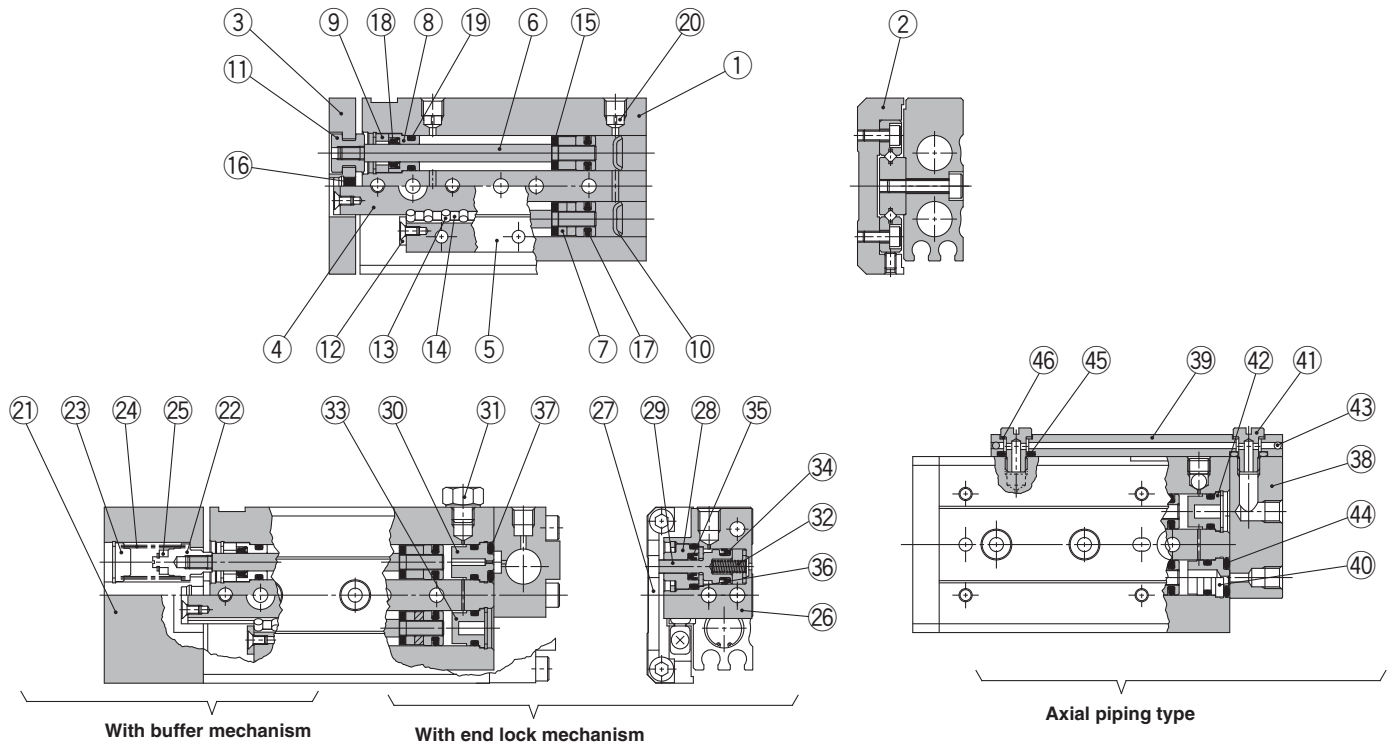
With buffer mechanism



With end lock

# Series MXS

## Construction



### Component Parts

No.	Description	Material	Note
1	Body	Aluminium alloy	Hard anodised
2	Table	Aluminium alloy	Hard anodised
3	End plate	Aluminium alloy	Hard anodised
4	Rail	Carbon tool steel	Heat treated
5	Guide	Carbon tool steel	Heat treated
6	Rod	Stainless steel	
7	Piston assembly	—	With magnet on one side
8	Rod cover	Aluminium alloy	Anodised
9	Seal support	Brass	High carbon chrome bearing steel
10	Head cap	Aluminium alloy	Hard anodised
11	Floating bushing	Stainless steel	
12	Roller stopper	Stainless steel	
13	Cylindrical roller	High carbon chrome bearing steel	
14	Roller spacer	Synthetic resin	
15	Rod bumper	Polyurethane	
16	End bumper	Polyurethane	
17	Piston seal	NBR	
18	Rod seal	NBR	
19	O-ring	NBR	
20	Orifice	06 (Basic type only) 08 to 16 (Basic type only)	Brass Synthetic resin Electroless nickel plated

### Component Parts: With Buffer

No.	Description	Material	Note
21	End plate	Aluminium alloy	Hard anodised
22	Spring collar	Stainless steel	
23	Head cap	Stainless steel	
24	Spring	Stainless steel	
25	Magnet	—	

### Replacement Parts/ Seal Kit

Bore size (mm)	Kit no.	Contents
6	MXS6-PS	Set of nos. above ⑰ to ⑲.
8	MXS8-PS	
12	MXS12-PS	
16	MXS16-PS	
20	MXS20-PS	
25	MXS25-PS	

### Replacement Parts/ Seal Kit for With End Lock

Bore size (mm)	Kit no.	Contents
8	MXS8R-PS	Set of nos. above ⑰ to ⑲
12	MXS12R-PS	
16	MXS16R-PS	⑳ to ㉓
20	MXS20R-PS	
25	MXS25R-PS	

### Component Parts: With End Lock

No.	Description	Material	Note
26	Locking body	Aluminium alloy	Hard anodised
27	Table support	Carbon steel	Anti-corrosive treated
28	Rod cover	Aluminium alloy	
29	Piston rod	Stainless steel	
30	Bushing	Aluminium alloy	Chromated
31	Blanking plug	Carbon steel	Nickel plated
32	Return spring	Stainless steel	
33	Head cap	Synthetic resin	
34	Piston seal	NBR	
35	Rod seal	NBR	
36	O-ring	NBR	
37	O-ring	NBR	

### Component Parts: Axial Piping Type

No.	Description	Material	Note
38	Axial piping plate	Aluminium alloy	Hard anodised
39	Pipe	Aluminium alloy	Hard anodised
40	Bushing	Aluminium alloy	Chromated
41	Stud	Brass	Electroless nickel plated
42	Head cap	Synthetic resin	
43	Steel balls	Stainless steel	
44	O-ring	NBR	
45	O-ring	NBR	
46	Gasket	NBR, Stainless steel	

\* Seal kit includes 1 set of numbered seals in the table below. Order the appropriate seal kit depending on the cylinder bore size.

### Replacement Parts/ Seal Kit for Axial Piping Type

Bore size (mm)	Kit no.	Contents
6	MXS6P-PS	Set of nos. above ⑰ to ⑲
8	MXS8P-PS	
12	MXS12P-PS	
16	MXS16P-PS	
20	MXS20P-PS	
25	MXS25P-PS	⑳ to ㉔

### Replacement Parts/ Grease Pack

Applied unit	Grease pack part no.
Guide unit	GR-S-010 (10g) GR-S-020 (20g)
Cylinder unit	GR-L-005 (5g) GR-L-010 (10g)

# Air Slide Table (Symmetric Type)

## Series **MXS□L**

### How to Order

Air slide table **MXS 12 □ L — 50 AS — M9N S**



**Port thread type**

-	M	ø6 to ø16
-	Rc	
TN	NPT	ø20, ø25
TF	G	

**Symmetric type**

**Bore size (Stroke (mm))**

6	10, 20, 30, 40, 50
8	10, 20, 30, 40, 50, 75
12	10, 20, 30, 40, 50, 75, 100
16	10, 20, 30, 40, 50, 75, 100, 125
20	10, 20, 30, 40, 50, 75, 100, 125, 150
25	10, 20, 30, 40, 50, 75, 100, 125, 150

**Number of auto switches**

-	2 pcs.
S	1 pc.
n	"n" pcs.

**Auto switch**

-	Without auto switch
---	---------------------

\* For the applicable auto switch models, refer to the table below.

**Adjuster option**

-	Without adjuster
AS	Adjuster on extension end
AT	Adjuster on retraction end
A	Adjuster on both ends
BS <sup>(1)</sup>	Absorber on extension end
BT <sup>(1)</sup>	Absorber on retraction end
B <sup>(1)</sup>	Absorber on both ends

Note 1) Options BS, BT and B are not available with the MXS6L series.  
 Note 2) Functional option is not available with the MXS□□L series.

### Specifications

Specifications are the same as the standard type. Refer to page 4.

### Applicable Auto Switches/Refer to "SMC Best Pneumatics" catalogue for further information on auto switches.

Type	Special function	Electrical entry	Indicator light	Wiring (Output)	Load voltage			Auto switch model		Lead wire length*			Pre-wired connector	Applicable load	
					DC	AC		Perpendicular	In-line	0.5 (Nil)	3 (L)	5 (Z)			
Reed switch	—	Grommet	Yes	3-wire (NPN equivalent)	—	5 V	—	A96V	A96	●	●	—	—	IC circuit	—
				2-wire	24 V	12 V	100 V	A93V	A93	●	●	—	—	—	Relay, PLC
Solid state switch	—	Grommet	Yes	3-wire (NPN)	24 V	5 V, 12 V	—	M9NV	M9N	●	●	○	○	IC circuit	Relay, PLC
				3-wire (PNP)				M9PV	M9P	●	●	○	○		
				2-wire				M9BV	M9B	●	●	○	○		
				3-wire (NPN)				M9NV	M9N	●	●	○	○		
				3-wire (PNP)				M9PV	M9P	●	●	○	○		
				2-wire				M9BV	M9B	●	●	○	○		
Diagnostic indication (2-colour indication)	—	Grommet	Yes	3-wire (NPN)	24 V	5 V, 12 V	—	M9NV	M9N	●	●	○	○	IC circuit	Relay, PLC
				3-wire (PNP)				M9PV	M9P	●	●	○	○		

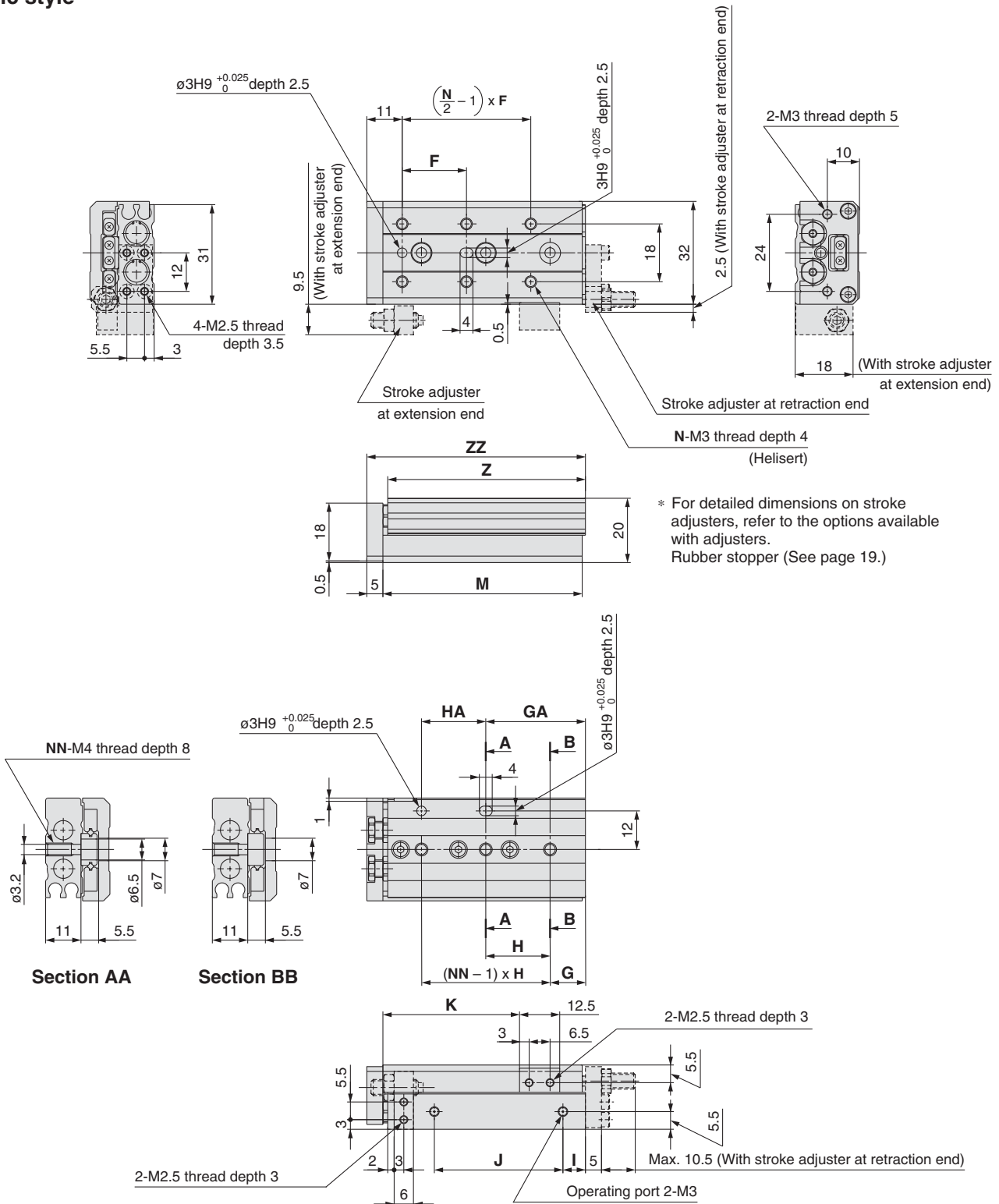
\* Lead wire length symbols: 0.5 m ..... Nil (Example) M9N      \* Solid state switches marked with "○" are produced upon receipt of order.  
 3 m ..... L (Example) M9NL  
 5 m ..... Z (Example) M9NZ

- Since there are additional applicable auto switches than are listed, refer to page 31.
- For details on auto switches with a pre-wired connector, refer to "SMC Best Pneumatics" catalogue.

# Series MXS

## Dimensions: MXS6L/Symmetric Type

### Basic style

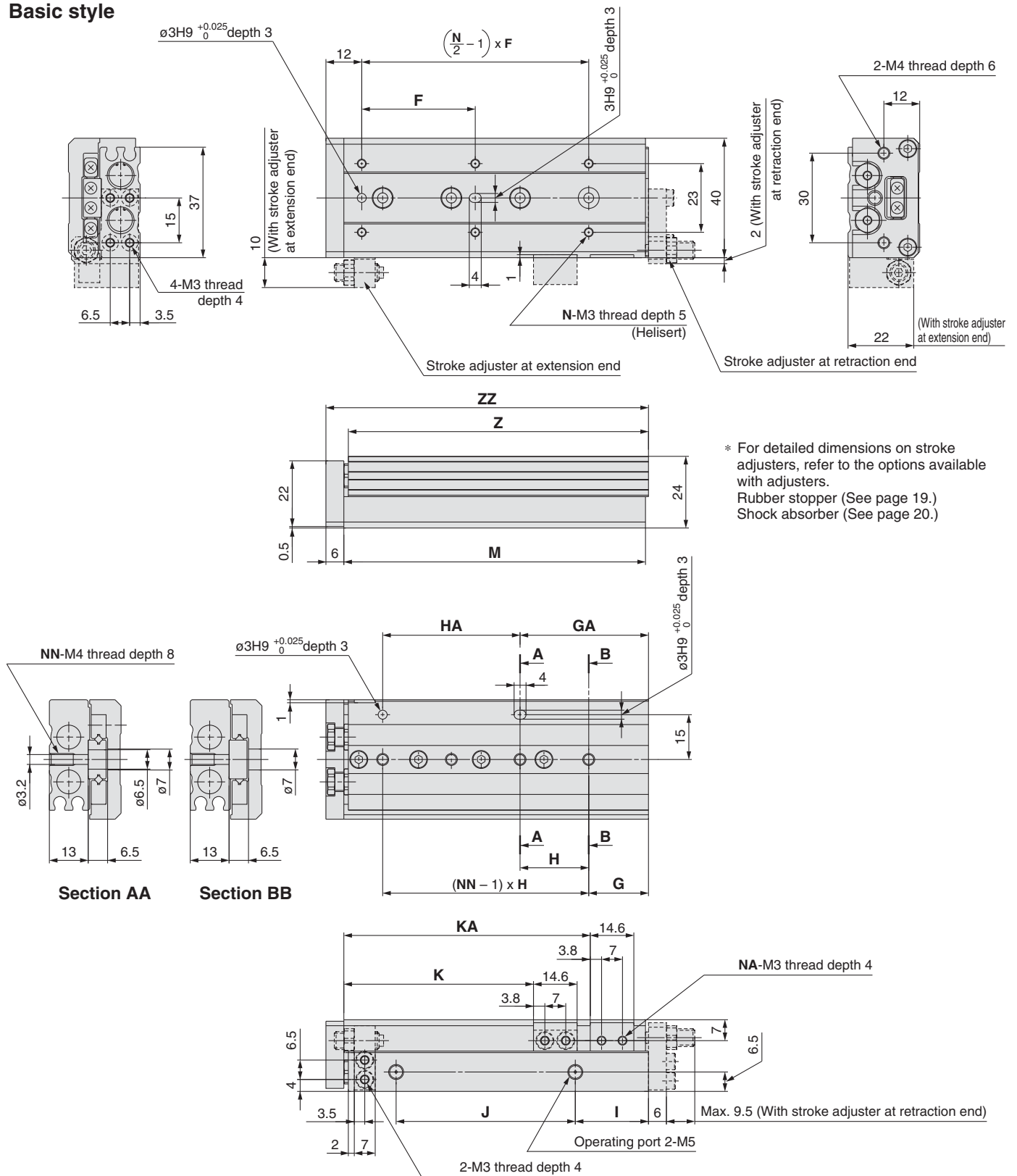


(mm)

Model	F	N	G	H	NN	GA	HA	I	J	K	M	Z	ZZ
MXS6L-10	20	4	6	25	2	11	20	10	17	22.5	42	41.5	48
MXS6L-20	30	4	6	35	2	21	20	10	27	32.5	52	51.5	58
MXS6L-30	20	6	11	20	3	31	20	7	40	42.5	62	61.5	68
MXS6L-40	28	6	13	30	3	43	30	19	50	52.5	84	83.5	90
MXS6L-50	38	6	17	24	4	41	48	25	60	62.5	100	99.5	106

**Dimensions: MXS8L/Symmetric Type**

**Basic style**



\* For detailed dimensions on stroke adjusters, refer to the options available with adjusters.  
 Rubber stopper (See page 19.)  
 Shock absorber (See page 20.)

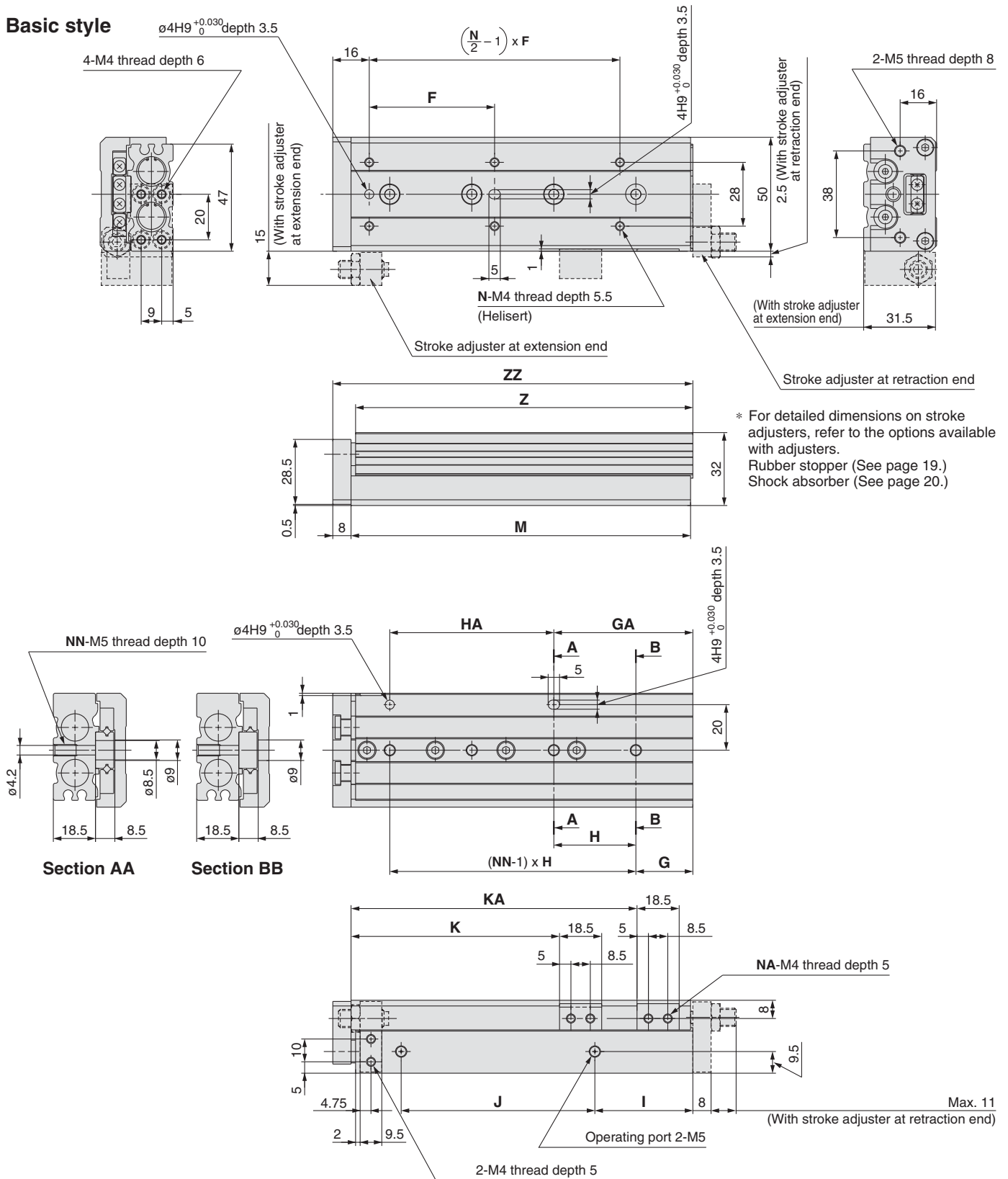
Model	F	N	G	H	NN	GA	HA	I	J	K	KA	NA	M	Z	ZZ
MXS8L-10	25	4	9	28	2	17	20	13	19.5	23.5	—	2	49	48.5	56
MXS8L-20	25	4	12	30	2	12	30	8.5	29	33.5	—	2	54	53.5	61
MXS8L-30	40	4	13	20	3	33	20	9.5	39	43.5	—	2	65	64.5	72
MXS8L-40	50	4	15	28	3	43	28	10.5	56	53.5	—	2	83	82.5	90
MXS8L-50	38	6	20	23	4	43	46	24.5	60	63.5	82.5	4	101	100.5	108
MXS8L-75	50	6	27	28	5	83	56	38.5	96	88.5	132.5	4	151	150.5	158

Regarding the external dimensions with a shock absorber, view the external dimensions of MXS8 symmetrically on page 10.

# Series MXS

## Dimensions: MXS12L/Symmetric Type

### Basic style

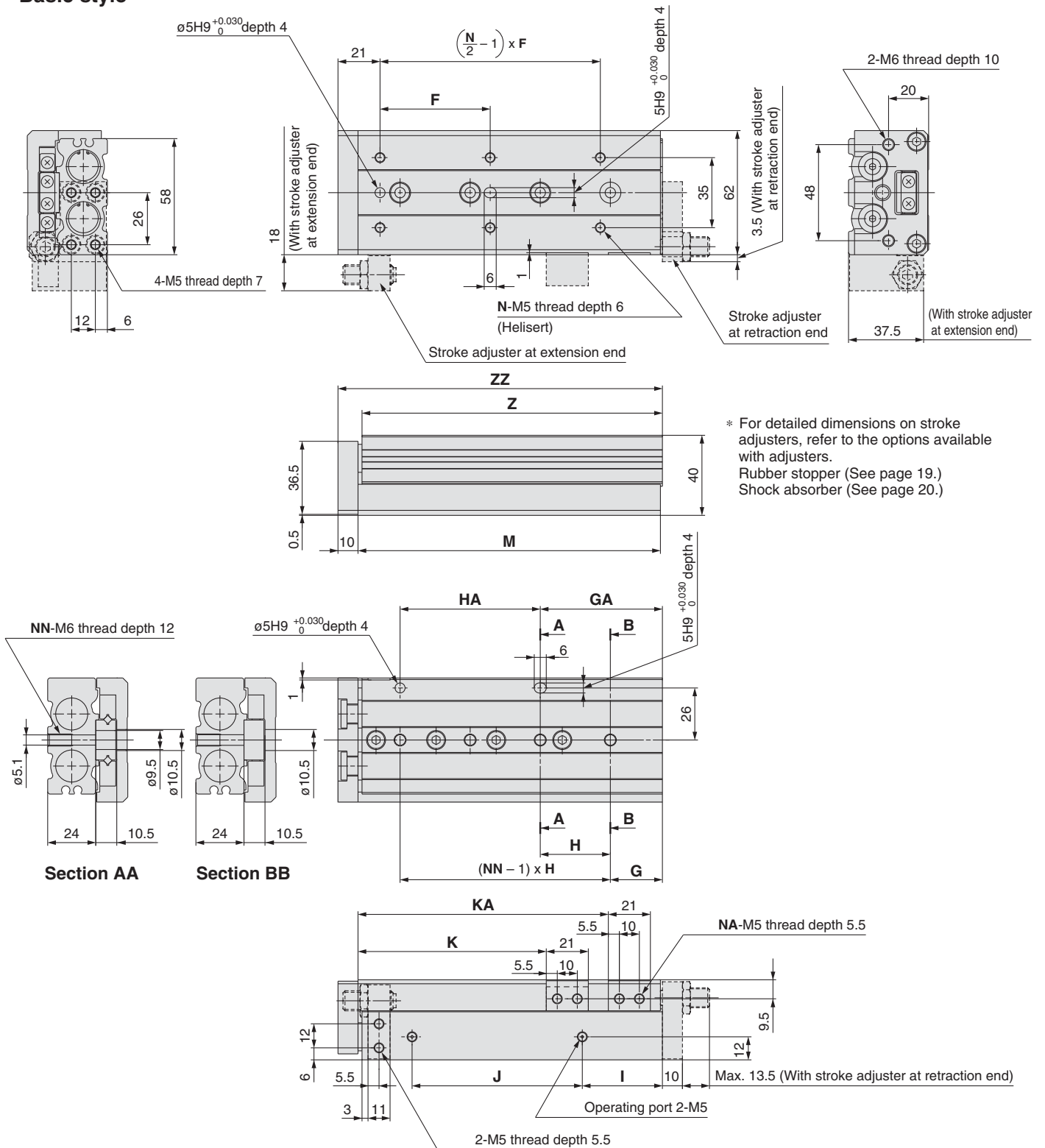


Model	F	N	G	H	NN	GA	HA	I	J	K	KA	NA	M	Z	ZZ
MXS12L-10	35	4	15	40	2	15	40	10	40	26.5	—	2	71	70	80
MXS12L-20	35	4	15	40	2	15	40	10	40	36.5	—	2	71	70	80
MXS12L-30	35	4	15	40	2	15	40	10	40	46.5	—	2	71	70	80
MXS12L-40	50	4	17	25	3	42	25	10	52	56.5	—	2	83	82	92
MXS12L-50	35	6	15	36	3	51	36	22	60	66.5	—	2	103	102	112
MXS12L-75	55	6	25	36	4	61	72	43	85	91.5	125.5	4	149	148	158
MXS12L-100	65	6	35	38	5	111	76	52	130	116.5	179.5	4	203	202	212

Regarding the external dimensions with a shock absorber, view the external dimensions of MXS12 symmetrically on page 12.

**Dimensions: MXS16L/Symmetric Type**

**Basic style**



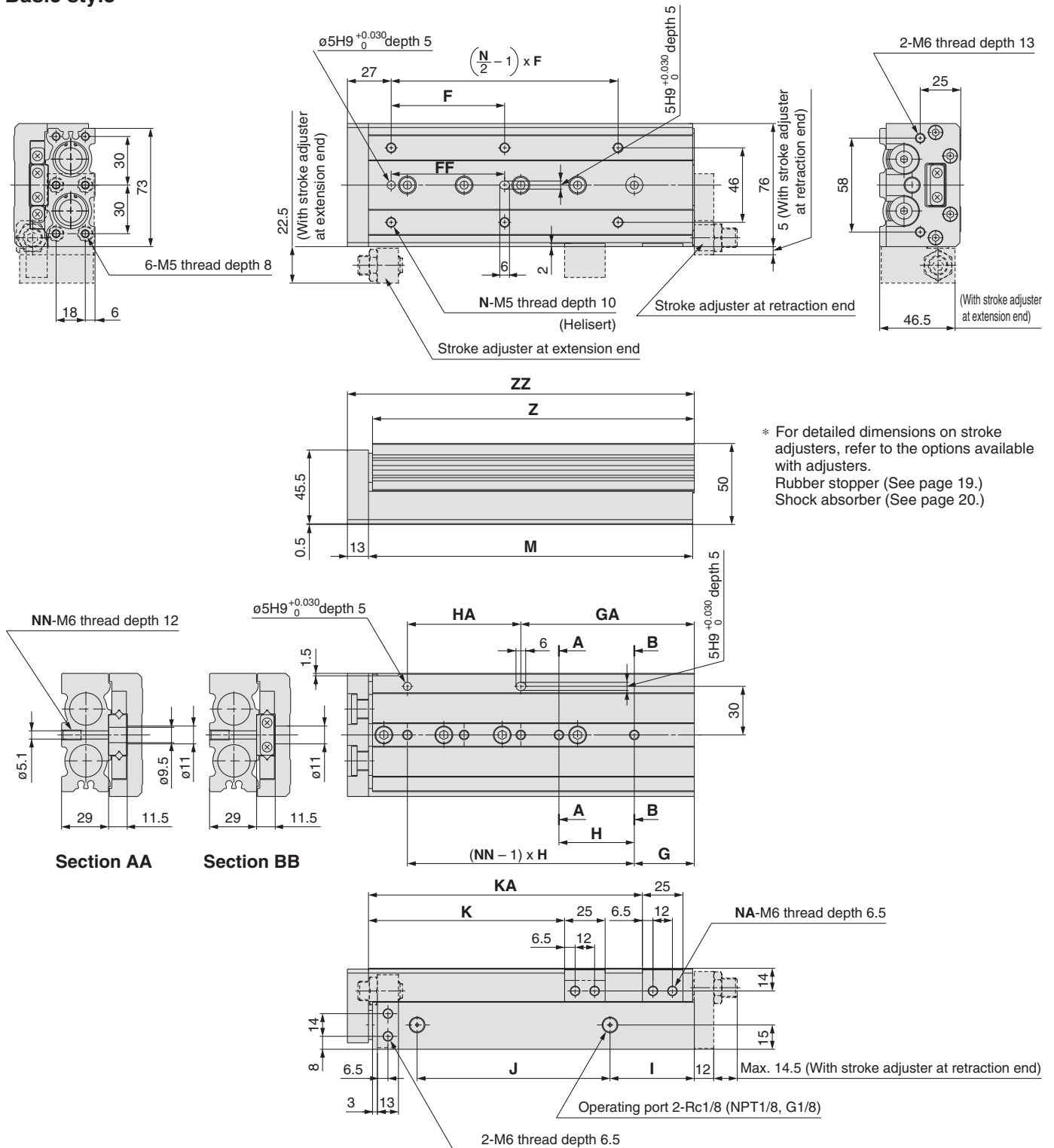
Model	F	N	G	H	NN	GA	HA	I	J	K	KA	NA	M	Z	ZZ
MXS16L-10	35	4	16	40	2	16	40	10	40	29	—	2	76	75	87
MXS16L-20	35	4	16	40	2	16	40	10	40	39	—	2	76	75	87
MXS16L-30	35	4	16	40	2	16	40	10	40	49	—	2	76	75	87
MXS16L-40	40	4	16	50	2	16	50	10	50	59	—	2	86	85	97
MXS16L-50	30	6	21	30	3	51	30	15	60	69	—	2	101	100	112
MXS16L-75	55	6	26	35	4	61	70	40	85	94	125	4	151	150	162
MXS16L-100	65	6	39	35	5	109	70	55	118	119	173	4	199	198	210
MXS16L-125	70	8	19	35	7	159	70	68	155	144	223	4	249	248	260

Regarding the external dimensions with a shock absorber, view the external dimensions of MXS16 symmetrically on page 14.

# Series MXS

## Dimensions: MXS20L/Symmetric Type

### Basic style



\* For detailed dimensions on stroke adjusters, refer to the options available with adjusters.  
 Rubber stopper (See page 19.)  
 Shock absorber (See page 20.)

Model	F	FF	N	G	H	NN	GA	HA	I	J	K	KA	NA	M	Z	ZZ
MXS20L-10	50	40	4	15	45	2	25	35	10	44	31	—	2	83	81.5	97
MXS20L-20	50	40	4	15	45	2	25	35	10	44	41	—	2	83	81.5	97
MXS20L-30	50	40	4	15	45	2	25	35	10	44	51	—	2	83	81.5	97
MXS20L-40	60	50	4	15	55	2	35	35	10	54	61	—	2	93	91.5	107
MXS20L-50	35	35	6	15	35	3	50	35	10	69	71	—	2	108	106.5	122
MXS20L-75	60	60	6	19	35	4	54	70	10	108	96	—	2	147	145.5	161
MXS20L-100	70	70	6	37	35	5	107	70	58	113	121	169	4	200	198.5	214
MXS20L-125	70	70	8	41	38	6	155	76	70	155	146	223	4	254	252.5	268
MXS20L-150	80	80	8	19	44	7	195	88	87	190	171	275	4	306	304.5	320

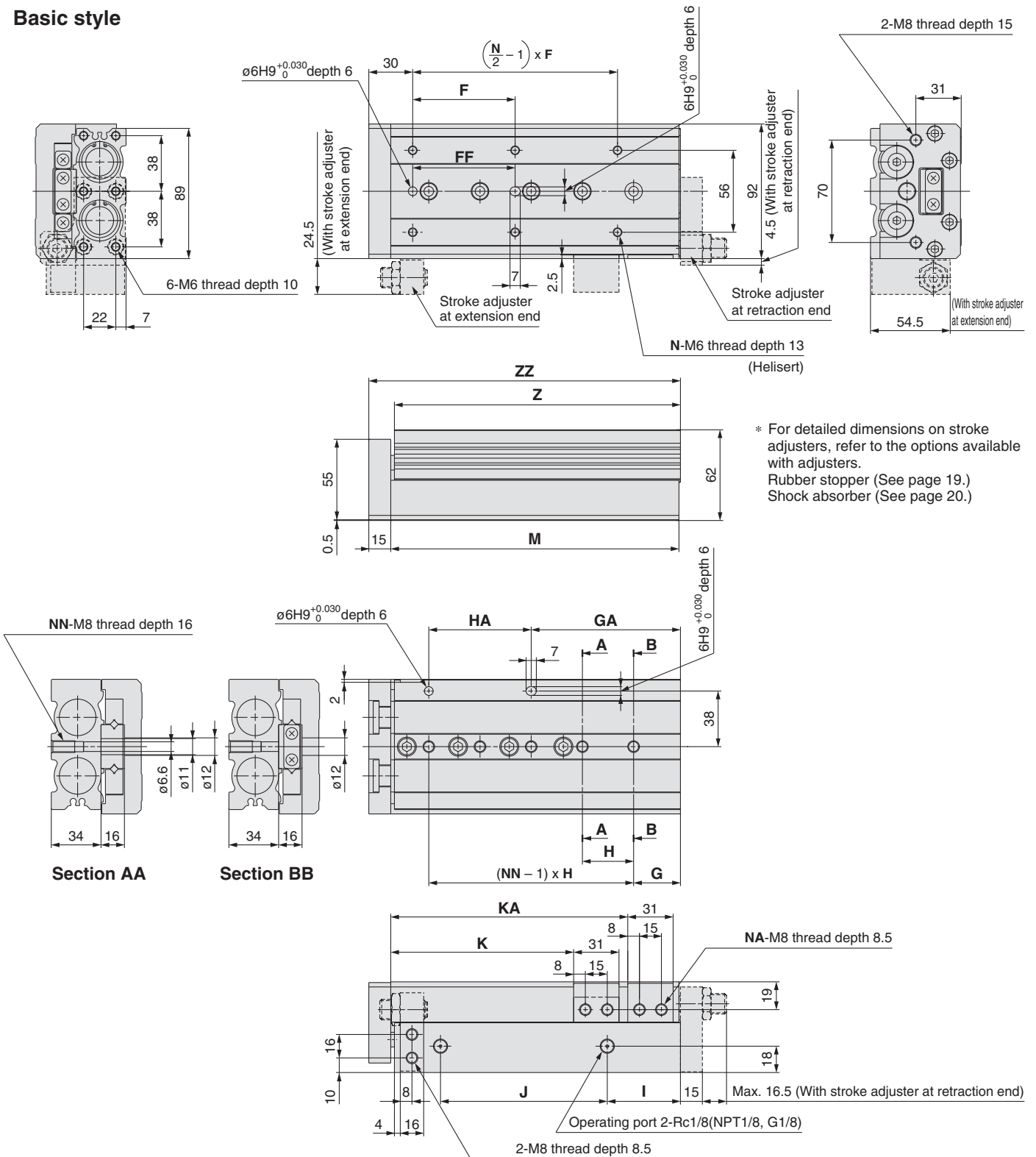
(mm)

Regarding the external dimensions with a shock absorber, view the external dimensions of MXS20 symmetrically on page 16.



**Dimensions: MXS25L/Symmetric Type**

**Basic style**

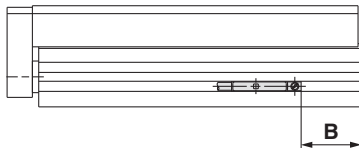
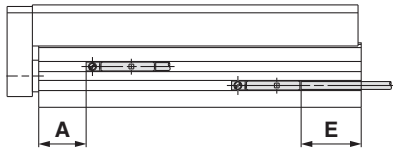


\* For detailed dimensions on stroke adjusters, refer to the options available with adjusters.  
 Rubber stopper (See page 19.)  
 Shock absorber (See page 20.)

Model	F	FF	N	G	H	NN	GA	HA	I	J	K	KA	NA	M	Z	ZZ
MXS25L-10	50	40	4	22	45	2	22	45	12	47	35	—	2	92	90.5	108
MXS25L-20	50	40	4	22	45	2	22	45	12	47	45	—	2	92	90.5	108
MXS25L-30	50	40	4	22	45	2	22	45	12	47	55	—	2	92	90.5	108
MXS25L-40	60	50	4	22	55	2	22	55	12	57	65	—	2	102	100.5	118
MXS25L-50	35	35	6	20	35	3	55	35	12	70	75	—	2	115	113.5	131
MXS25L-75	60	60	6	26	35	4	61	70	33	90	100	—	2	156	154.5	172
MXS25L-100	70	70	6	32	35	5	102	70	50	114	125	162	4	197	195.5	213
MXS25L-125	75	75	8	40	38	6	154	76	67	155	150	218	4	255	253.5	271
MXS25L-150	80	80	8	30	40	7	190	80	82	180	175	258	4	295	293.5	311

Regarding the external dimensions with a shock absorber, view the external dimensions of MXS25 symmetrically on page 18.

## Proper Position for Auto Switch Mounting (Detection at stroke end)



### Reed Switch: D-A90, D-A93, D-A96, D-A90V, D-A93V, D-A96V

Model	A	B										E									
		Stroke										Stroke									
		10	20	30	40	50	75	100	125	150	10	20	30	40	50	75	100	125	150		
MXS6	5.9	5.6	5.6	5.6	17.6	23.6	—	—	—	—	3.6 (1.1)	3.6 (1.1)	3.6 (1.1)	15.6 (13.1)	21.6 (19.1)	—	—	—	—		
MXS8	7.6	10.9	5.9	6.9	14.9	22.9	47.9	—	—	—	8.9 (6.4)	3.9 (1.4)	4.9 (2.4)	12.9 (10.4)	20.9 (18.4)	45.9 (43.4)	—	—	—		
MXS12	11.6	28.4	18.4	8.4	10.4	20.4	41.4	70.4	—	—	26.4 (23.9)	16.4 (13.9)	6.4 (3.9)	8.4 (5.9)	18.4 (15.9)	39.4 (36.9)	68.4 (65.9)	—	—		
MXS16	16.3	28.7	18.7	8.7	8.7	13.7	38.7	61.7	86.7	—	26.7 (24.2)	16.7 (14.2)	6.7 (4.2)	6.7 (4.2)	11.7 (9.2)	36.7 (34.2)	59.7 (57.2)	84.7 (82.2)	—		
MXS20	18.9	32.6	22.6	12.6	12.6	17.6	31.6	59.6	88.6	115.6	30.6 (28.1)	20.6 (18.1)	10.6 (8.1)	10.6 (8.1)	15.6 (13.1)	29.6 (27.1)	57.6 (55.1)	86.6 (84.1)	113.6 (111.1)		
MXS25	23	37.5	27.5	17.5	17.5	20.5	36.5	52.5	85.5	100.5	35.5 (33)	25.5 (23)	15.5 (13)	15.5 (13)	18.5 (16)	34.5 (32)	50.5 (48)	83.5 (81)	98.5 (96)		

\* ( ): Denotes D-A93.

### Solid State Switch: D-M9B, D-M9N, D-M9P, D-M9BW, D-M9NW, D-M9PW

Model	A	B										E									
		Stroke										Stroke									
		10	20	30	40	50	75	100	125	150	10	20	30	40	50	75	100	125	150		
MXS6	10	9.6	9.6	9.6	21.6	27.6	—	—	—	—	-0.4	-0.4	-0.4	11.6	17.5	—	—	—	—		
MXS8	11.6	14.9	9.9	10.9	18.9	26.9	51.9	—	—	—	4.9	-0.1	0.9	8.9	16.9	41.9	—	—	—		
MXS12	15.6	32.4	22.4	12.4	14.4	24.4	45.4	74.4	—	—	22.4	12.4	2.4	4.4	14.4	35.4	64.4	—	—		
MXS16	20.3	32.7	22.7	12.7	12.7	17.7	42.7	65.7	90.7	—	22.7	12.7	2.7	2.7	7.7	32.7	55.7	80.7	—		
MXS20	22.9	36.6	26.6	16.6	16.6	21.6	35.6	63.6	92.6	119.6	26.6	16.6	6.6	6.6	11.6	25.6	53.6	82.6	109.6		
MXS25	27	41.5	31.5	21.5	21.5	24.5	40.5	56.5	89.5	104.5	31.5	21.5	11.5	11.5	14.5	30.5	46.5	79.5	94.5		

### Solid State Switch: D-M9BV, D-M9NV, D-M9PV, D-M9BWV, D-M9NWV, D-M9PWV

Model	A	B										E									
		Stroke										Stroke									
		10	20	30	40	50	75	100	125	150	10	20	30	40	50	75	100	125	150		
MXS6	10	9.6	9.6	9.6	21.6	27.6	—	—	—	—	1.6	1.6	1.6	13.6	19.6	—	—	—	—		
MXS8	11.6	14.9	9.9	10.9	18.9	26.9	51.9	—	—	—	6.9	1.9	2.9	10.9	18.9	43.9	—	—	—		
MXS12	15.6	32.4	22.4	12.4	14.4	24.4	45.4	74.4	—	—	24.4	14.4	4.4	6.4	16.4	37.4	66.4	—	—		
MXS16	20.3	32.7	22.7	12.7	12.7	17.7	42.7	65.7	90.7	—	24.7	14.7	4.7	4.7	9.7	34.7	57.7	82.7	—		
MXS20	22.9	36.6	26.6	16.6	16.6	21.6	35.6	63.6	92.6	119.6	28.6	18.6	8.6	8.6	13.6	27.6	55.6	84.6	111.6		
MXS25	27	41.5	31.5	21.5	21.5	24.5	40.5	56.5	89.5	104.5	33.5	23.5	13.5	13.5	16.5	32.5	48.5	81.5	96.5		

## Auto Switch Mounting



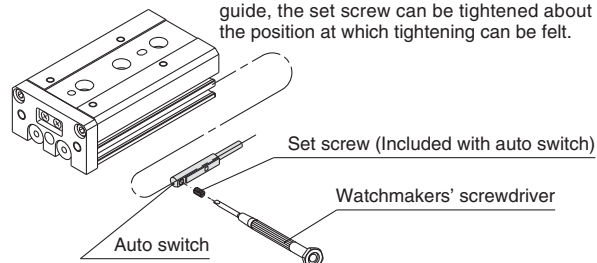
### Caution

#### Auto Switch Mounting Tool

- When tightening the auto switch mounting screw (included with auto switch), use a watchmakers' screwdriver with an approximately 5 to 6 mm diameter handle.

#### Tightening Torque

- Use a torque of approximately 0.05 to 0.1 N·m. As a guide, the set screw can be tightened about 90° past the position at which tightening can be felt.



## Operating Range

(mm)

Auto switch model	Applicable bore size (mm)					
	6	8	12	16	20	25
D-A9□/A9□V	4.5	5	6	7	8	8
D-M9□/M9□V	1.5	1.5	2.5	3	3	3
D-M9□W/M9□WV	2	2.5	3	4	6	6

Other than the applicable auto switches listed in "How to Order", the following auto switches can be mounted. For detailed specifications, refer to "SMC Best Pneumatics" catalogue.

Type	Model	Electrical entry (direction)	Features
Reed switch	D-A90	Grommet (In-line)	Without indicator light
	D-A90V	Grommet (Perpendicular)	

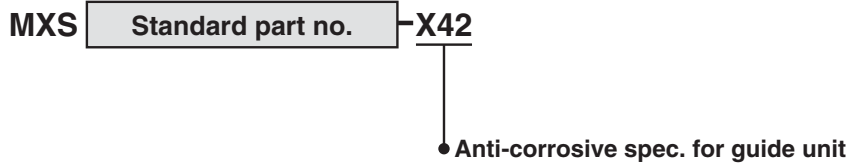
\* Normally closed (NC=b contact), solid state switch (D-F9G/F9H type) are also available. For details, refer to "SMC Best Pneumatics" catalogue.

# Series MXS Made to Order

Contact SMC for detailed dimensions, specifications and delivery.



	Symbol
Anti-corrosive spec. for guide unit	<b>-X42</b>



The rail and guide block undergo an anti-corrosive treatment.

## Specifications

Model	Anti-corrosive specification type
Bore size (mm)	6, 8, 12, 16, 20, 25
Fluid	Air
Surface treatment	Special anti-corrosive treatment <sup>Note 2)</sup>

Note 1) Dimensions are the same as the standard type.

Note 2) The rail and guide are black due to the special anti-corrosive treatment.






Series **MXS**

# Safety Instructions

These safety instructions are intended to prevent a hazardous situation and/or equipment damage. These instructions indicate the level of potential hazard by labels of "**Caution**", "**Warning**" or "**Danger**". To ensure safety, be sure to observe ISO 4414 <sup>Note 1)</sup>, JIS B 8370 <sup>Note 2)</sup> and other safety practices.

## ■ Explanation of the labels

Labels	Explanation of the labels
 <b>Danger</b>	In extreme conditions, there is a possible result of serious injury or loss of life.
 <b>Warning</b>	Operator error could result in serious injury or loss of life.
 <b>Caution</b>	Operator error could result in injury or equipment damage.

Note 1) ISO 4414: Pneumatic fluid power – General rules relating to systems

Note 2) JIS B 8370: General Rules for Pneumatic Equipment

Note 3) Injury indicates light wounds, burns and electrical shocks that do not require hospitalisation or hospital visits for long-term medical treatment.

Note 4) Equipment damage refers to extensive damage to the equipment and surrounding devices.

## ■ Selection/Handling/Applications

### 1. The compatibility of the pneumatic equipment is the responsibility of the person who designs the pneumatic system or decides its specifications.

Since the products specified here are used in various operating conditions, their compatibility for the specific pneumatic system must be based on specifications or post analysis and/or tests to meet the specific requirements. The expected performance and safety assurance are the responsibility of the person who has determined the compatibility of the system. This person should continuously review the suitability of all items specified, referring to the latest catalogue information with a view to giving due consideration to any possibility of equipment failure when configuring a system.

### 2. Only trained personnel should operate pneumatically operated machinery and equipment.

Compressed air can be dangerous if handled incorrectly. Assembly, handling or repair of pneumatic systems should be performed by trained and experienced operators.

### 3. Do not service machinery/equipment or attempt to remove components until safety is confirmed.

1. Inspection and maintenance of machinery/equipment should only be performed once measures to prevent falling or runaway of the driver objects have been confirmed.
2. When equipment is removed, confirm that safety process as mentioned above. Turn off the supply pressure for this equipment and exhaust all residual compressed air in the system.
3. Before machinery/equipment is restarted, take measures to prevent quick extension of a cylinder piston rod, etc.

### 4. Contact SMC if the product will be used in any of the following conditions:

1. Conditions and environments beyond the given specifications, or if product is used outdoors.
2. Installation on equipment in conjunction with atomic energy, railway, air navigation, vehicles, medical equipment, food and beverages, recreation equipment, emergency stop circuits, clutch and brake circuits in press applications, or safety equipment.
3. An application which has the possibility of having negative effects on people, property, or animals, requiring special safety analysis.
4. If the products are used in an interlock circuit, prepare a double interlock style circuit with a mechanical protection function for the prevention of a breakdown. And, examine the devices periodically if they function normally or not.

## ■ Exemption from liability

1. SMC, its officers and employees shall be exempted from liability for any loss or damage arising out of earthquakes or fire, action by a third person, accidents, customer error with or without intention, product misuse, and any other damages caused by abnormal operating conditions.
2. SMC, its officers and employees shall be exempted from liability for any direct or indirect loss or damage, including consequential loss or damage, loss of profits, or loss of chance, claims, demands, proceedings, costs, expenses, awards, judgments and any other liability whatsoever including legal costs and expenses, which may be suffered or incurred, whether in tort (including negligence), contract, breach of statutory duty, equity or otherwise.
3. SMC is exempted from liability for any damages caused by operations not contained in the catalogues and/or instruction manuals, and operations outside of the specification range.
4. SMC is exempted from liability for any loss or damage whatsoever caused by malfunctions of its products when combined with other devices or software.



# Series MXS

## Specific Product Precautions 1

Be sure to read this before handling. For Safety Instructions, Actuators Precaution, Auto Switches Precautions, refer to "Precautions for Handling Pneumatic Devices" (M-03-E3A)

### Selection

#### ⚠ Caution

1. Operate a load within the range of the operating limits.

#### Operate loads within the range of the operating limits.

When the actuator is used outside the operating limits, excentric loads on the guide will be excessive and this will cause vibration on the guide, in accuracy and shortened life.

2. If intermediate stops by external stopper is done, avoid ejection.

If lurching occurs, damage can result. When making an intermediate stop with an external stopper to be followed by continued forward movement, first supply pressure to momentarily reverse the table, then retract the intermediate stopper, and finally apply pressure to the opposite port to operate the table again.

3. Do not use it in such a way that excessive external force or impact force could work on it.

This could result in damage.

### Mounting

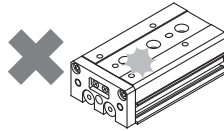
#### ⚠ Caution

1. Do not scratch or dent the mounting side of the body, table or end plate.

The damage will result in a decrease in parallelism, vibration of the guide or an increase in moving part resistance.

2. Do not scratch or dent on the forward side of the rail or guide.

This could result in looseness, increased operating resistance, etc.



3. Do not apply excessive power and load when work is mounted.

If an external force more than the allowable moment is applied, looseness of the guide unit or increased operating resistance could take place.

4. Flatness of mounting surface should be 0.02 mm or less.

Poor parallelism of the workpiece mounted on the air slide table, the base, and other parts can cause vibration in the guide unit and increased operating resistance, etc.

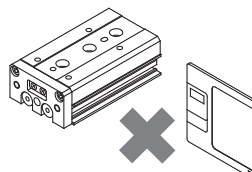
5. Select the proper connection with the load which has external support and/or guide mechanism on the outside, and align it properly.

6. Avoid contact with the air slide table during operation.

Hands, etc. may get caught in the stroke adjuster. Install a cover as a safety measure if there are instances to be near the slide table during operation.

7. Keep away from objects which are influenced by magnets.

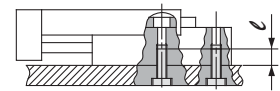
Since an air slide table has magnets built-in, do not allow close contact with magnetic disks, magnetic cards or magnetic tapes. Data may be erased.



8. Do not attach magnets to the table section.

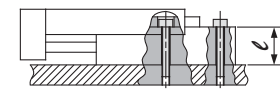
Since the table is constructed with a magnetic substance, it becomes magnetised when magnets, etc. are attached to it. This may cause malfunction of auto switches, etc.

#### 1. Lateral mounting (Body tapped)



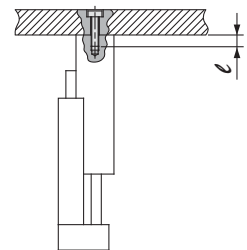
Model	Bolt	Maximum tightening torque (N·m)	Maximum screw-in depth (ℓ mm)
MXS6	M4	2.1	8
MXS8	M4	2.1	8
MXS12	M5	4.4	10
MXS16	M6	7.4	12
MXS20	M6	7.4	12
MXS25	M8	18	16

#### 2. Lateral mounting (Through-hole)



Model	Bolt	Maximum tightening torque (N·m)	Maximum screw-in depth (ℓ mm)
MXS6	M3	1.2	11
MXS8	M3	1.2	13
MXS12	M4	2.8	18.5
MXS16	M5	5.7	24
MXS20	M5	5.7	29
MXS25	M6	10	34

#### 3. Vertical mounting (Body tapped)



Model	Bolt	Maximum tightening torque (N·m)	Maximum screw-in depth (ℓ mm)
MXS6	M2.5	0.5	3.5
MXS8	M3	0.9	4
MXS12	M4	2.1	6
MXS16	M5	4.4	7
MXS20	M5	4.4	8
MXS25	M6	7.4	10



# Series MXS

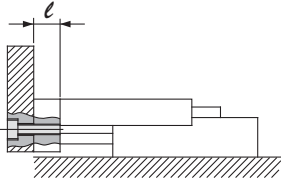
## Specific Product Precautions 2

Be sure to read this before handling. For Safety Instructions, Actuators Precaution, Auto Switches Precautions, refer to “Precautions for Handling Pneumatic Devices” (M-03-E3A)

### Mounting

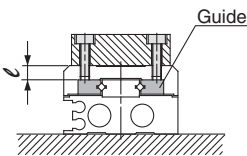
#### ⚠ Caution

##### 1. Front mounting



Model	Bolt	Maximum tightening torque (N·m)	Maximum screw-in depth (l mm)
MXS6	M3	0.9	5
MXS8	M4	2.1	6
MXS12	M5	4.4	8
MXS16	M6	7.4	10
MXS20	M6	7.4	13
MXS25	M8	18	15

##### 2. Top mounting



**⚠ Caution** To prevent the workpiece holding bolts from touching the guide block, use bolts that are at least 0.5 mm shorter than the maximum screw-in depth. If longer bolts are used, they can touch the guide and cause a malfunction.

Model	Bolt	Maximum tightening torque (N·m)	Maximum screw-in depth (l mm)
MXS6	M3	0.9	4
MXS8	M3	0.9	5
MXS12	M4	2.1	5.5
MXS16	M5	4.4	10
MXS20	M5	4.4	10
MXS25	M6	7.4	13

1. The positioning hole on the table and the positioning hole at the bottom of the body do not have the same centre. Use these holes during reinstallation after the table has been removed for the maintenance of an identical product.

### Operating Environment

#### ⚠ Caution

1. Do not use in an environment, where the product could be exposed to liquids such as cutting oil, etc.

Using in an environment where the product could be exposed to cutting oil, coolant, oil, etc. could result in looseness, increased operating resistance, air leakage, etc.

2. Do not use in an environment, where the product could be exposed directly to foreign materials such as powder dust, blown dust, cutting chips, spatter, etc.

This could result in looseness and increased operating resistance, and air leakage, etc.

Contact us regarding use in this kind of environment.

3. Do not use in direct sunlight.
4. When there are heat sources in the surrounding area, block them off.

When there are heat sources in the surrounding area, radiated heat may cause the product's temperature to rise and exceed the operating temperature range. Block off the heat with a cover, etc.

5. Do not subject it to excessive vibration and/or impact.

Contact us regarding use in this kind of environment, since this can cause damage or a malfunction.

### Caution on Handling Adjuster Option

#### Stroke Adjuster

#### ⚠ Caution

1. Do not replace with the bolt other than the original adjusting bolt.

This could result in looseness and damage due to impact forces, etc.

2. Refer to the table below for the lock nut tightening torque.

Insufficient torque will cause a decrease in the positioning accuracy.

Model	Tightening torque (N·m)
MXS6	3.0
MXS8	5.0
MXS12	12.5
MXS16	25.0
MXS20	43.0
MXS25	69.0

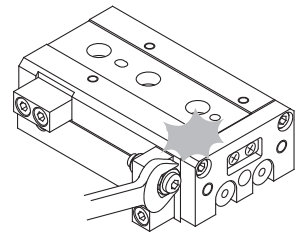
### Caution on Handling Adjuster Option

#### Stroke Adjuster

#### ⚠ Caution

3. When stroke adjuster is adjusted, do not hit the table with a wrench, etc.

This could result in looseness.



### With Shock Absorber

#### ⚠ Caution

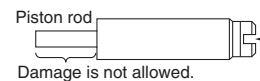
1. Do not rotate the set screw on the bottom of shock absorber.

This is not an adjusting screw. Turning it could cause oil leakage.

2. Do not scratch the exposed portion of the piston rod.

Durability could be degraded and the piston rod may not retract.

Turning the bottom screw is not allowed.



3. Shock absorber is considered a consumable component. When energy absorption has decreased, replace it.

Applicable size	Shock absorber model
MXS8	RB0805
MXS12	RB0806
MXS16	RB1007
MXS20	RB1411
MXS25	RB1412

4. Refer to the table below for the tightening torque of the lock nut for the shock absorber.

Model	Tightening torque (N·m)
MXS8	1.67
MXS16	3.14
MXS20	10.8
MXS25	



# Series MXS

## Specific Product Precautions 3

Be sure to read this before handling. For Safety Instructions, Actuators Precaution, Auto Switches Precautions, refer to “Precautions for Handling Pneumatic Devices” (M-03-E3A)

### Caution on Mounting Adjuster Option

#### Rubber Stopper

### ⚠ Caution

**1. Use caution because the lengths of the mounting bolts for the body and the table are different from each other for some models.**

The shock absorber at the extension end (AS) of the MXS6, 8 and 12 has different length hexagon socket head cap screws on the body mounting section and on the table mounting section. Use sufficient care when mounting.

If assembled by making an error in length, it could cause looseness or lead to malfunction.

**2. Follow the table below for tightening torque of mounting bolts.**

Insufficient torque will cause a decrease in the positioning accuracy and lead to malfunction.

Model	Stroke adjuster at extension end (AS)				Stroke adjuster at retraction end (AT)	
	Body mounting section		Table mounting section		Thread size	Tightening torque (N·m)
	Thread size	Tightening torque (N·m)	Thread size	Tightening torque (N·m)		
<b>MXS6</b>	M2.5 x 10	0.5	M2.5 x 8	0.5	M2.5 x 8	0.5
<b>MXS8</b>	M3 x 12	0.9	M3 x 10	0.9	M3 x 10	0.9
<b>MXS12</b>	M4 x 15	2.1	M4 x 12	2.1	M4 x 8	2.1
<b>MXS16</b>	M5 x 18	4.4	M5 x 18	4.4	M5 x 10	4.4
<b>MXS20</b>	M6 x 20	7.0	M6 x 20	7.0	M5 x 12	4.4
<b>MXS25</b>	M8 x 25	18.0	M8 x 25	18.0	M6 x 16	7.0

#### Shock Absorber

### ⚠ Caution

**1. Use caution because the lengths of the mounting bolts for the body and the table are different from each other for some models.**

The shock absorber at the retraction end (BT) has different length hexagon socket head cap screws on the body mounting section and on the table mounting section. Use sufficient care when mounting.

If assembled by making an error in length, it could cause looseness or lead to malfunction.

**2. Follow the table below for tightening torque of mounting bolts.**

Insufficient torque will cause a decrease in the positioning accuracy and lead to malfunction.

Model	Shock absorber at extension end (BS)				Shock absorber at retraction end (BT)			
	Body mounting section		Table mounting section		Body mounting section		Table mounting section	
	Thread size	Tightening torque (N·m)	Thread size	Tightening torque (N·m)	Thread size	Tightening torque (N·m)	Thread size	Tightening torque (N·m)
<b>MXS8</b>	M3 x 16	0.9	M3 x 16	0.9	M3 x 12	0.9	M3 x 16	0.9
<b>MXS12</b>	M4 x 15	2.1	M4 x 15	2.1	M4 x 8	2.1	M4 x 15	2.1
<b>MXS16</b>	M5 x 18	4.4	M5 x 18	4.4	M5 x 10	4.4	M5 x 18	4.4
<b>MXS20</b>	M6 x 25	7.0	M6 x 25	7.0	M5 x 12	4.4	M6 x 25	7.0
<b>MXS25</b>	M8 x 25	18.0	M8 x 25	18.0	M6 x 16	7.0	M8 x 25	18.0



# Series MXS

## Specific Product Precautions 4

Be sure to read this before handling. For Safety Instructions, Actuators Precaution, Auto Switches Precautions, refer to "Precautions for Handling Pneumatic Devices" (M-03-E3A)

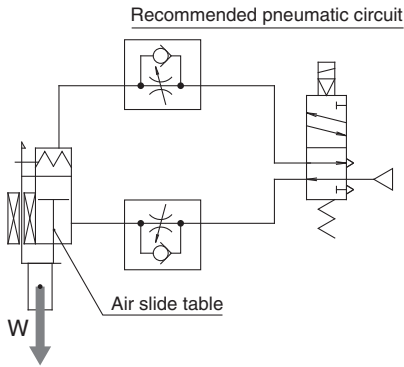
### Caution on Handling Functional Option

#### With End Lock

#### ⚠ Caution

##### 1. Use 2 position, 4 or 5 port solenoid valves.

A malfunction may occur with a control circuit that exhausts from both ports, such as exhaust centre 3 position valves.



##### 2. Be sure to use meter-out speed control valves.

If used with meter-in speed control or without a speed controller, it may result in malfunction.

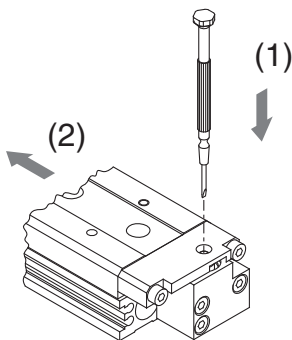
##### 3. When releasing the end lock manually, be sure that air pressure is released.

If the end lock is unlocked while the air pressure still remains, it will lead to damage of the workpiece, etc. due to unexpected lurching.

#### How to Unlock the End Lock

\* Before proceeding, make sure that there is no residual air pressure.

- (1) Push down the lock piston pin.
- (2) Slide the table forward.

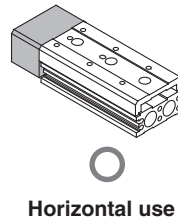
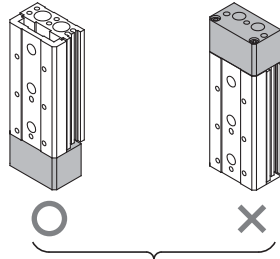


#### With Buffer Mechanism

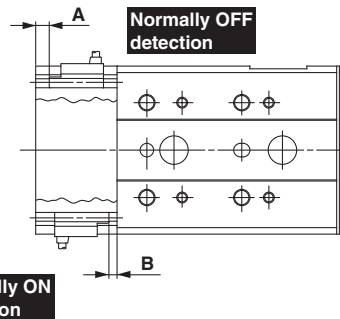
#### ⚠ Caution

##### 1. When using the air slide table with buffer, it must be oriented as shown in the sketch below.

In horizontal operation, the buffer may travel the stroke length and activate the auto switch depending on the load and the speed. Therefore, adjust the speed according to the load.



##### 2. Auto switch with buffer function: For the proper mounting positions for detection at stroke end, refer to the following table.



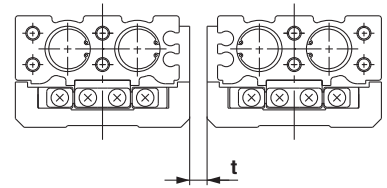
\* Adjust the switch position according to load and speed.

(mm)		
Model	A	B
MXS6	2	3
MXS8	2.5	
MXS12	4	
MXS16	5	
MXS20	5.5	
MXS25	10	

### Caution on Handling Symmetric Type

##### 1. Maintain a longer distance than prescribed below if standard style and symmetric style are used side by side.

If the space is insufficient, it may cause auto switches to malfunction.






(mm)	
Model	Mounting pitch: t
MXS6	5
MXS8	10
MXS12	10
MXS16	10
MXS20	15
MXS25	15



## Safety Instructions

These safety instructions are intended to prevent hazardous situations and/or equipment damage. These instructions indicate the level of potential hazard with the labels of “Caution,” “Warning” or “Danger.” They are all important notes for safety and must be followed in addition to International Standards (ISO/IEC)\*1, and other safety regulations.

-  **Caution:** **Caution** indicates a hazard with a low level of risk which, if not avoided, could result in minor or moderate injury.
-  **Warning:** **Warning** indicates a hazard with a medium level of risk which, if not avoided, could result in death or serious injury.
-  **Danger:** **Danger** indicates a hazard with a high level of risk which, if not avoided, will result in death or serious injury.

- \*1) ISO 4414: Pneumatic fluid power – General rules relating to systems.  
ISO 4413: Hydraulic fluid power – General rules relating to systems.  
IEC 60204-1: Safety of machinery – Electrical equipment of machines.  
(Part 1: General requirements)
- ISO 10218-1: Manipulating industrial robots - Safety.  
etc.

### Warning

#### 1. The compatibility of the product is the responsibility of the person who designs the equipment or decides its specifications.

Since the product specified here is used under various operating conditions, its compatibility with specific equipment must be decided by the person who designs the equipment or decides its specifications based on necessary analysis and test results. The expected performance and safety assurance of the equipment will be the responsibility of the person who has determined its compatibility with the product. This person should also continuously review all specifications of the product referring to its latest catalogue information, with a view to giving due consideration to any possibility of equipment failure when configuring the equipment.

#### 2. Only personnel with appropriate training should operate machinery and equipment.

The product specified here may become unsafe if handled incorrectly. The assembly, operation and maintenance of machines or equipment including our products must be performed by an operator who is appropriately trained and experienced.

#### 3. Do not service or attempt to remove product and machinery/equipment until safety is confirmed.

1. The inspection and maintenance of machinery/equipment should only be performed after measures to prevent falling or runaway of the driven objects have been confirmed.
2. When the product is to be removed, confirm that the safety measures as mentioned above are implemented and the power from any appropriate source is cut, and read and understand the specific product precautions of all relevant products carefully.
3. Before machinery/equipment is restarted, take measures to prevent unexpected operation and malfunction.

#### 4. Contact SMC beforehand and take special consideration of safety measures if the product is to be used in any of the following conditions.

1. Conditions and environments outside of the given specifications, or use outdoors or in a place exposed to direct sunlight.
2. Installation on equipment in conjunction with atomic energy, railways, air navigation, space, shipping, vehicles, military, medical treatment, combustion and recreation, or equipment in contact with food and beverages, emergency stop circuits, clutch and brake circuits in press applications, safety equipment or other applications unsuitable for the standard specifications described in the product catalogue.
3. An application which could have negative effects on people, property, or animals requiring special safety analysis.
4. Use in an interlock circuit, which requires the provision of double interlock for possible failure by using a mechanical protective function, and periodical checks to confirm proper operation.

## Limited warranty and Disclaimer/ Compliance Requirements

The product used is subject to the following “Limited warranty and Disclaimer” and “Compliance Requirements”.

Read and accept them before using the product.

### Limited warranty and Disclaimer

1. The warranty period of the product is 1 year in service or 1.5 years after the product is delivered, whichever is first.\*2) Also, the product may have specified durability, running distance or replacement parts. Please consult your nearest sales branch.
2. For any failure or damage reported within the warranty period which is clearly our responsibility, a replacement product or necessary parts will be provided. This limited warranty applies only to our product independently, and not to any other damage incurred due to the failure of the product.
3. Prior to using SMC products, please read and understand the warranty terms and disclaimers noted in the specified catalogue for the particular products.

\*2) Vacuum pads are excluded from this 1 year warranty.

A vacuum pad is a consumable part, so it is warranted for a year after it is delivered. Also, even within the warranty period, the wear of a product due to the use of the vacuum pad or failure due to the deterioration of rubber material are not covered by the limited warranty.

### Compliance Requirements

1. The use of SMC products with production equipment for the manufacture of weapons of mass destruction (WMD) or any other weapon is strictly prohibited.
2. The exports of SMC products or technology from one country to another are governed by the relevant security laws and regulations of the countries involved in the transaction. Prior to the shipment of a SMC product to another country, assure that all local rules governing that export are known and followed.

### Caution

#### 1. The product is provided for use in manufacturing industries.

The product herein described is basically provided for peaceful use in manufacturing industries.

If considering using the product in other industries, consult SMC beforehand and exchange specifications or a contract if necessary.

If anything is unclear, contact your nearest sales branch.

### Caution

#### SMC products are not intended for use as instruments for legal metrology.

Measurement instruments that SMC manufactures or sells have not been qualified by type approval tests relevant to the metrology (measurement) laws of each country.

Therefore, SMC products cannot be used for business or certification ordained by the metrology (measurement) laws of each country.

## Safety Instructions

Be sure to read “Handling Precautions for SMC Products” (M-E03-3) before using.

### SMC Corporation (Europe)

Austria	☎+43 (0)2262622800	www.smc.at	office@smc.at	Lithuania	☎+370 5 2308118	www.smclt.lt	info@smclt.lt
Belgium	☎+32 (0)33551464	www.smc.be	info@smc.be	Netherlands	☎+31 (0)205318888	www.smc.nl	info@smc.nl
Bulgaria	☎+359 (0)2807670	www.smc.bg	office@smc.bg	Norway	☎+47 67129020	www.smc-norge.no	post@smc-norge.no
Croatia	☎+385 (0)13707288	www.smc.hr	office@smc.hr	Poland	☎+48 222119600	www.smc.pl	office@smc.pl
Czech Republic	☎+420 541424611	www.smc.cz	office@smc.cz	Portugal	☎+351 214724500	www.smc.eu	apoioclientept@smc.smces.es
Denmark	☎+45 70252900	www.smcdk.com	smc@smcdk.com	Romania	☎+40 213205111	www.smcromania.ro	smcromania@smcromania.ro
Estonia	☎+372 6510370	www.smc pneumatic.smc.ee	smc@smc pneumatic.smc.ee	Russia	☎+7 8127185445	www.smc-pneumatik.ru	info@smc-pneumatik.ru
Finland	☎+358 207513513	www.smc.fi	smc fi@smc.fi	Slovakia	☎+421 (0)413213212	www.smc.sk	office@smc.sk
France	☎+33 (0)164761000	www.smc-france.fr	info@smc-france.fr	Slovenia	☎+386 (0)73885412	www.smc.si	office@smc.si
Germany	☎+49 (0)61034020	www.smc.de	info@smc.de	Spain	☎+34 945184100	www.smc.es	post@smc.smces.es
Greece	☎+30 210 2717265	www.smc hellas.gr	sales@smc hellas.gr	Sweden	☎+46 (0)86031200	www.smc.nu	post@smc.nu
Hungary	☎+36 23513000	www.smc.hu	office@smc.hu	Switzerland	☎+41 (0)523963131	www.smc.ch	info@smc.ch
Ireland	☎+353 (0)14039000	www.smc pneumatic.smc.ie	sales@smc pneumatic.smc.ie	Turkey	☎+90 212 489 0 440	www.smc pnomatik.com.tr	info@smc pnomatik.com.tr
Italy	☎+39 0292711	www.smcitalia.it	mailbox@smcitalia.it	UK	☎+44 (0)845 121 5122	www.smc.uk	sales@smc.uk
Latvia	☎+371 67817700	www.smc.lv	info@smc.lv				